



(19) **United States**  
(12) **Patent Application Publication**  
**Masuda**

(10) **Pub. No.: US 2014/0184059 A1**  
(43) **Pub. Date: Jul. 3, 2014**

(54) **DISPLAY PANEL AND DISPLAY PANEL MANUFACTURING METHOD**

**Publication Classification**

(71) Applicant: **PANASONIC CORPORATION**, Osaka (JP)

(51) **Int. Cl.**  
**H05B 33/04** (2006.01)  
**H05B 33/10** (2006.01)

(72) Inventor: **Hiroyuki Masuda**, Hyogo (JP)

(52) **U.S. Cl.**  
CPC ..... **H05B 33/04** (2013.01); **H05B 33/10** (2013.01)  
USPC ..... **313/512; 445/25**

(73) Assignee: **PANASONIC CORPORATION**, Osaka (JP)

(57) **ABSTRACT**

(21) Appl. No.: **14/240,416**

A display panel comprises a first substrate, a second substrate arranged opposite the first substrate, electroluminescence elements disposed between the first substrate and the second substrate, and a sealing member provided between the first substrate and the second substrate, sealing the electroluminescence elements. The sealing member includes a rectangular frame formed along a perimeter of the electroluminescence elements and a reinforced portion protruding outward from a corner portion of the rectangular frame, the reinforced portion includes a first side face cut so as to be flush with at least one corner side face of the first substrate, and a second side face cut so as to be flush with a corresponding corner side face of the second substrate.

(22) PCT Filed: **May 17, 2013**

(86) PCT No.: **PCT/JP2013/003156**

§ 371 (c)(1),  
(2), (4) Date: **Feb. 24, 2014**

(30) **Foreign Application Priority Data**

May 18, 2012 (JP) ..... 2012-114850

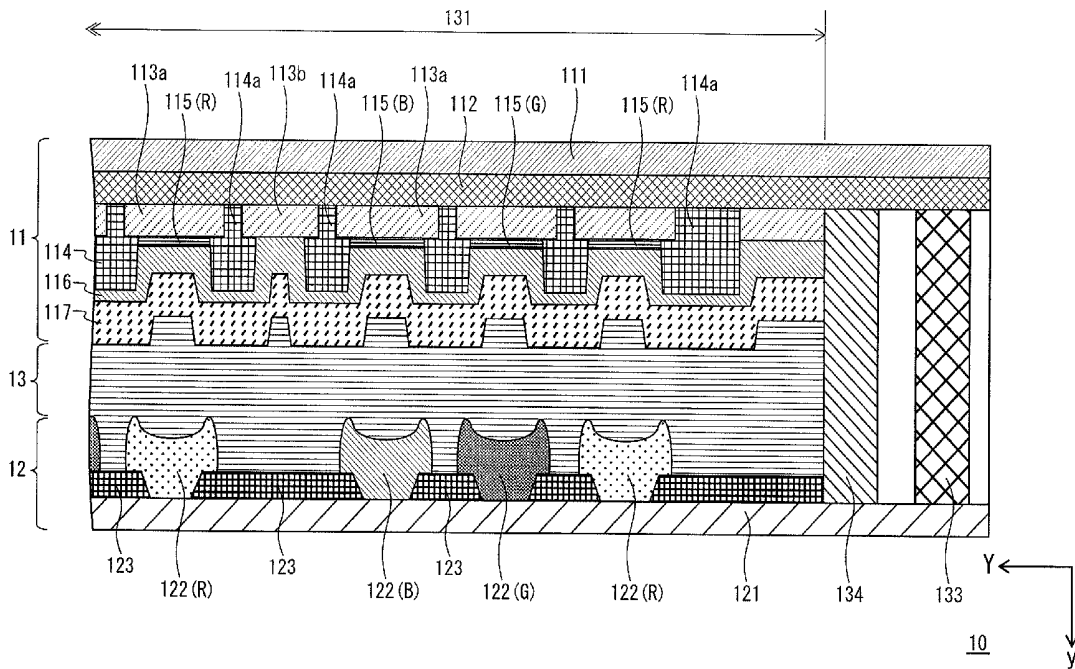

FIG. 1

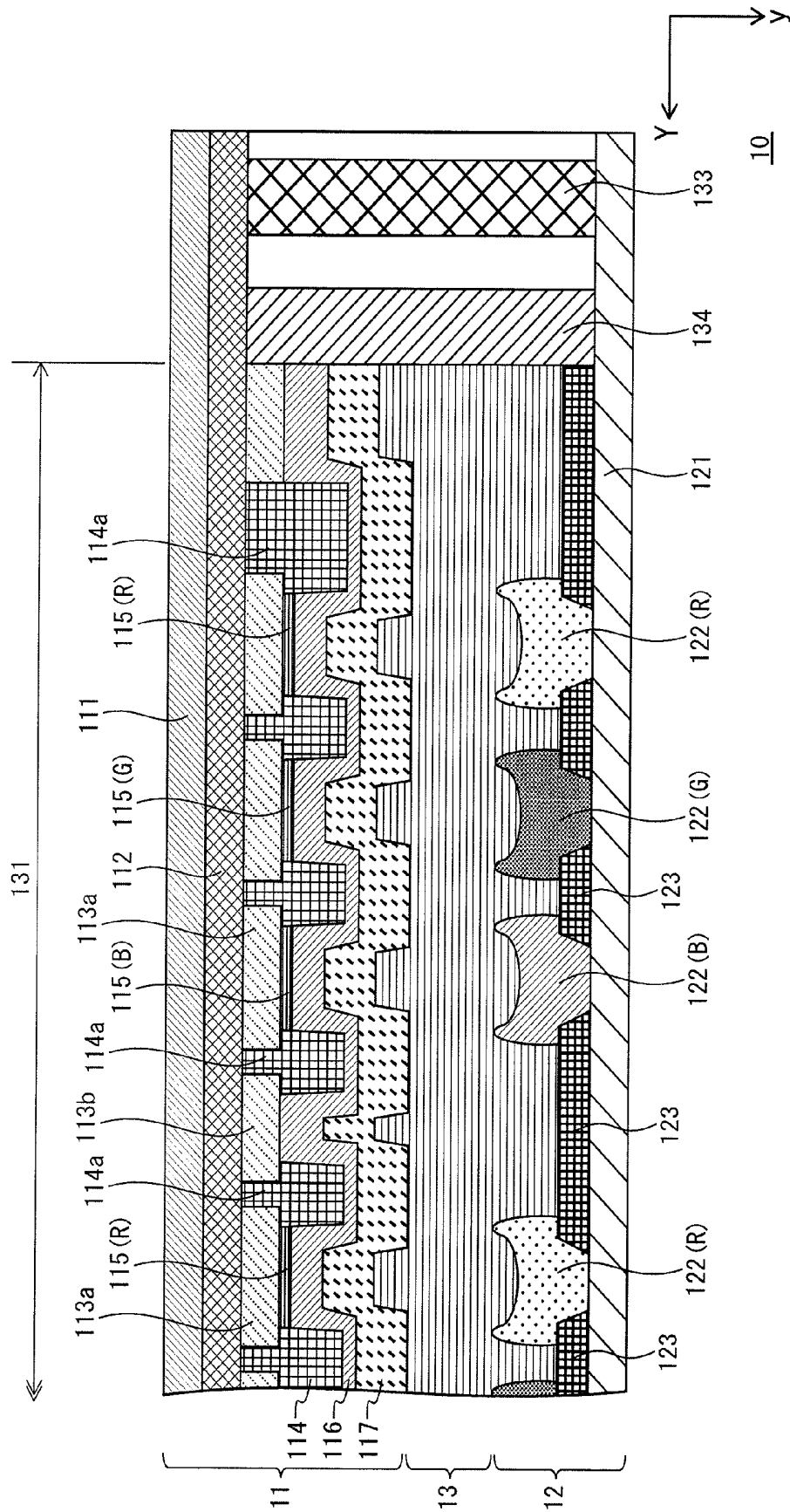

FIG. 2

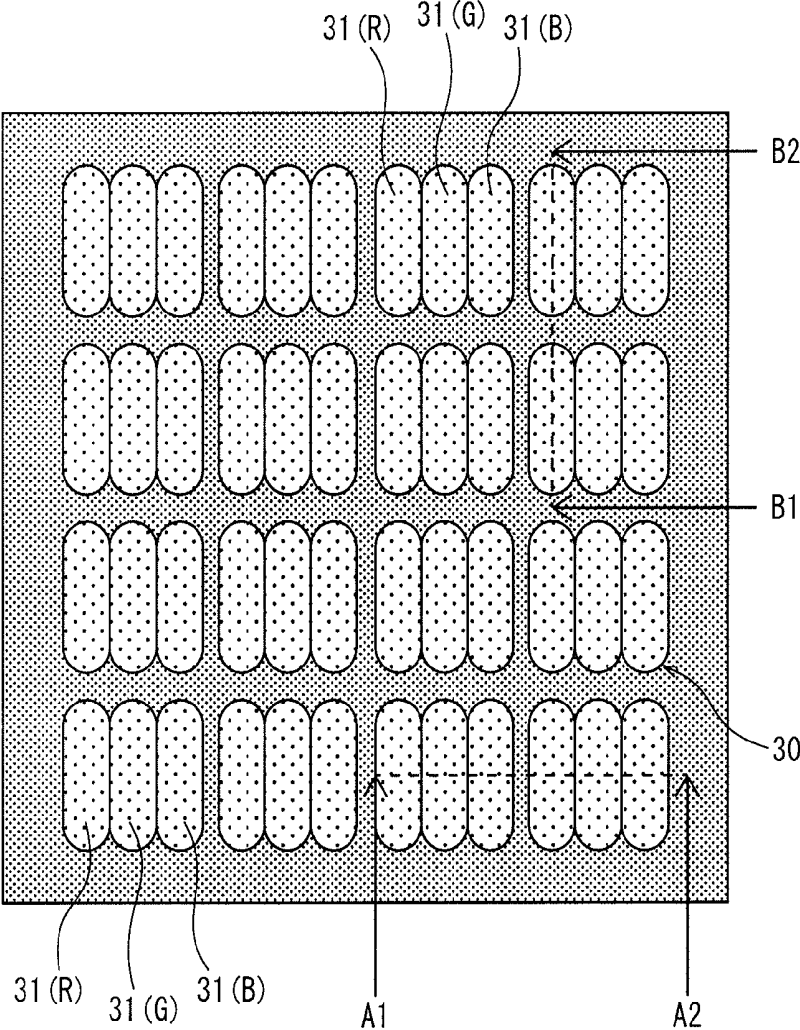

FIG. 3

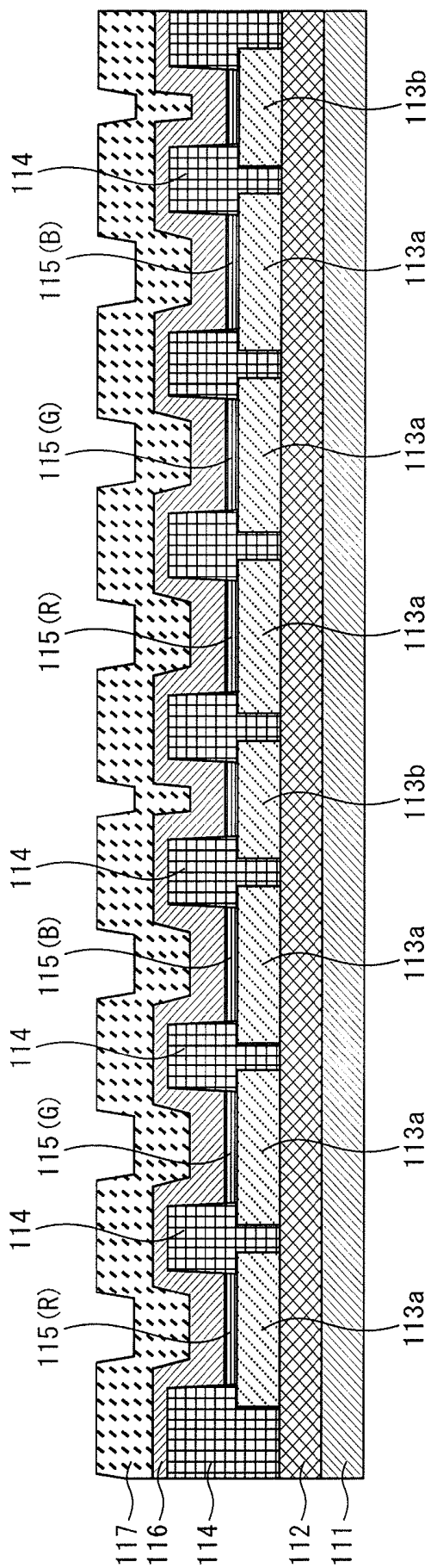

FIG. 4

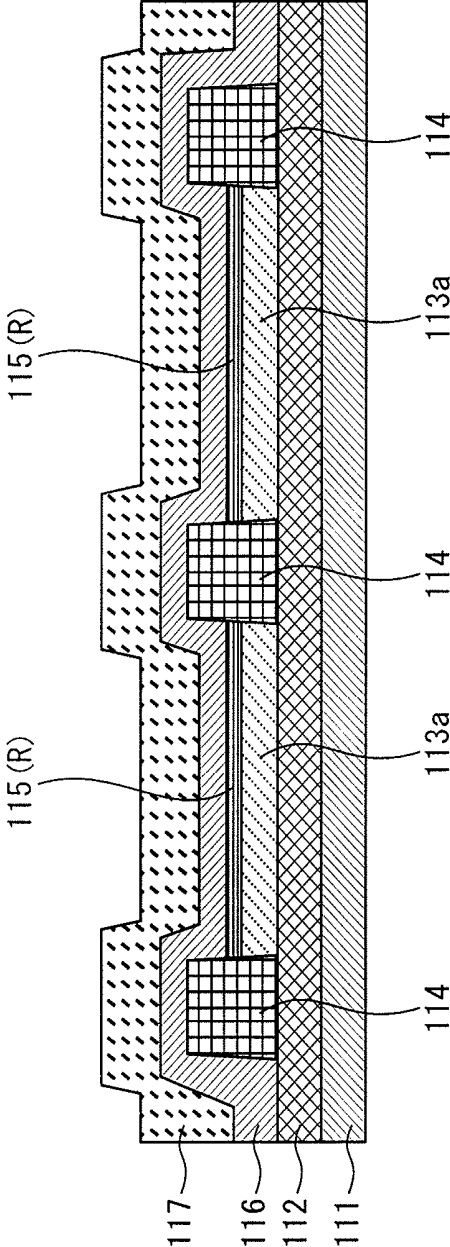

FIG. 5

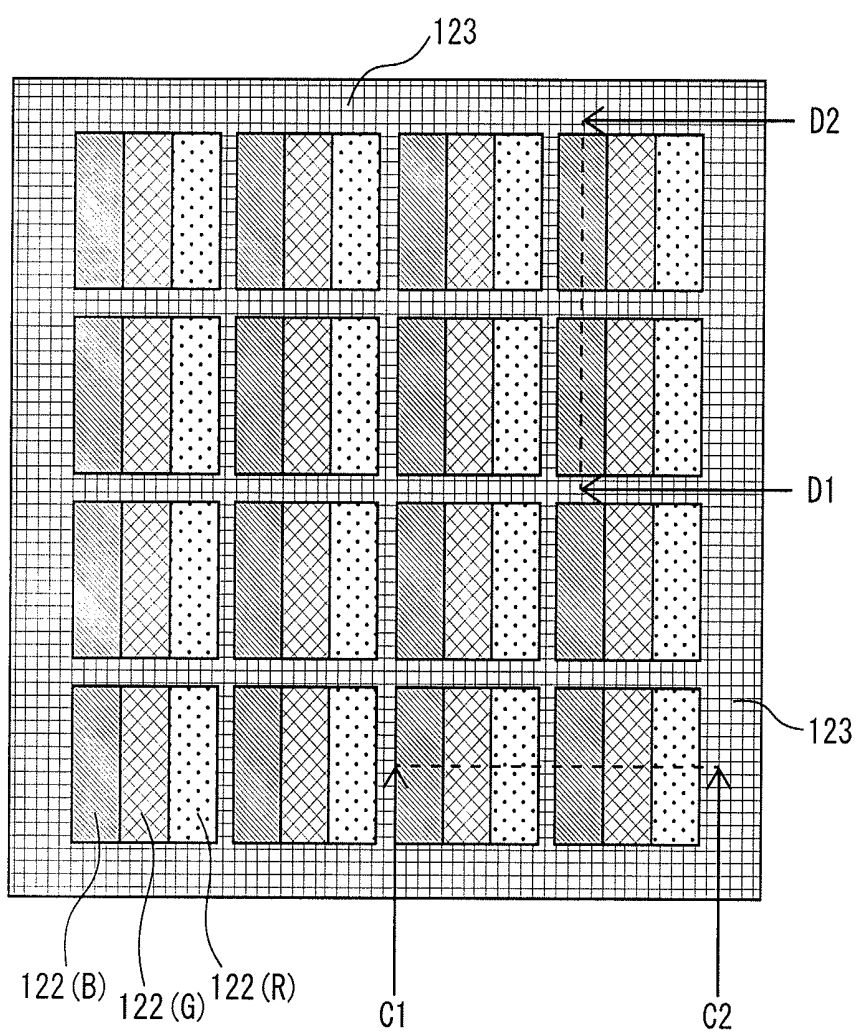

FIG. 6

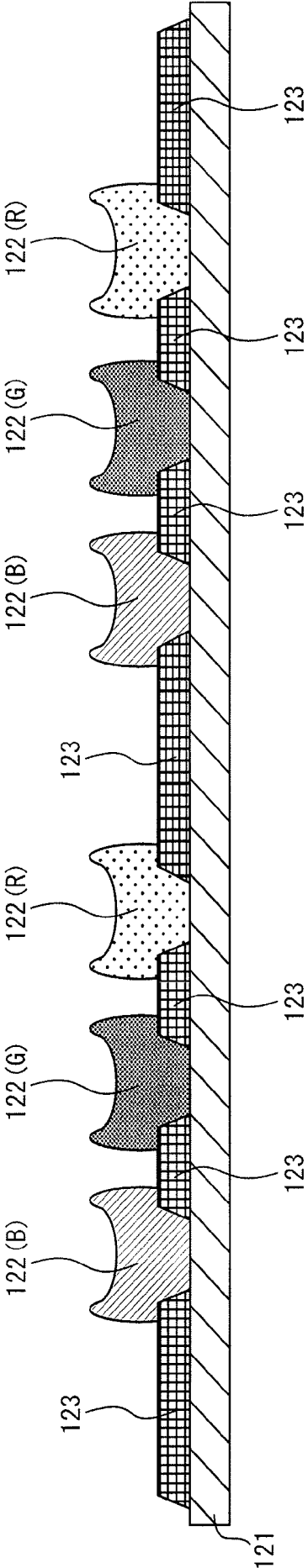

FIG. 7

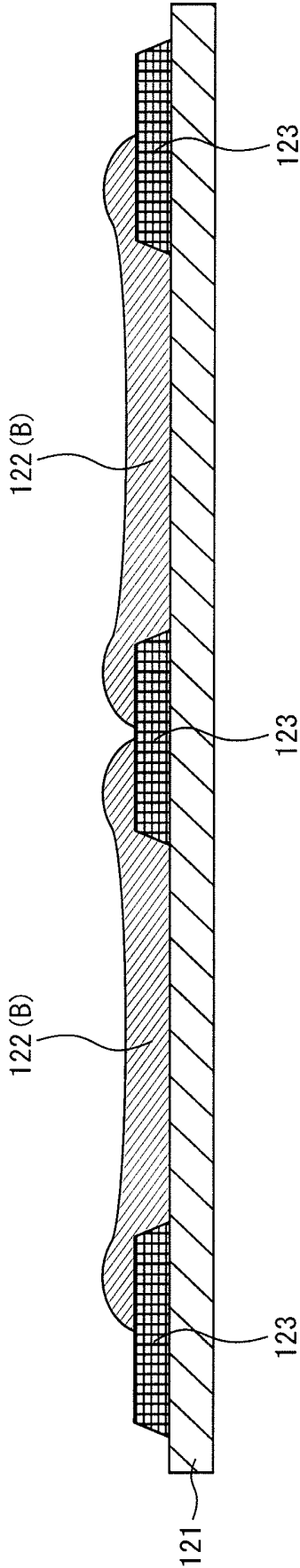

FIG. 8A

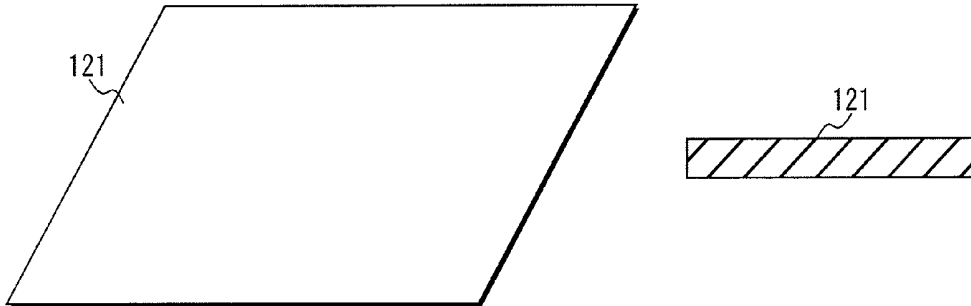

FIG. 8B

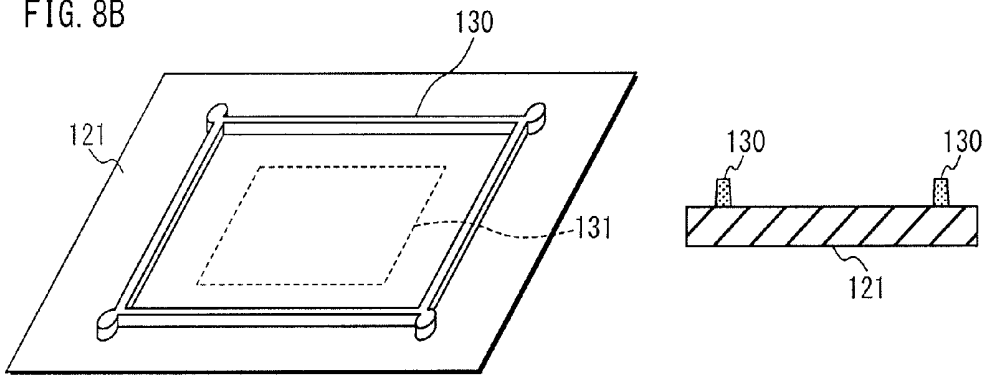

FIG. 8C

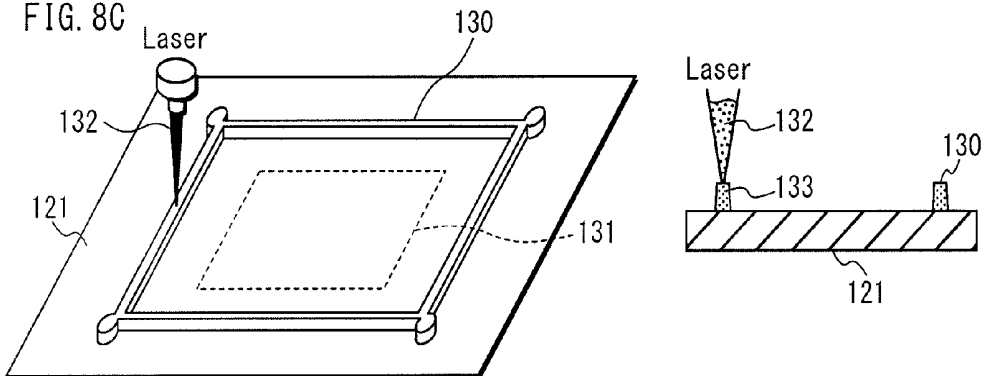

FIG. 8D

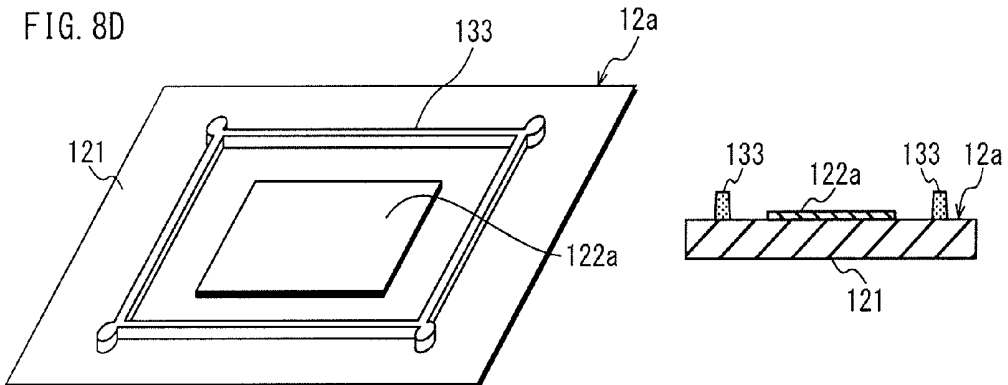



FIG. 10A

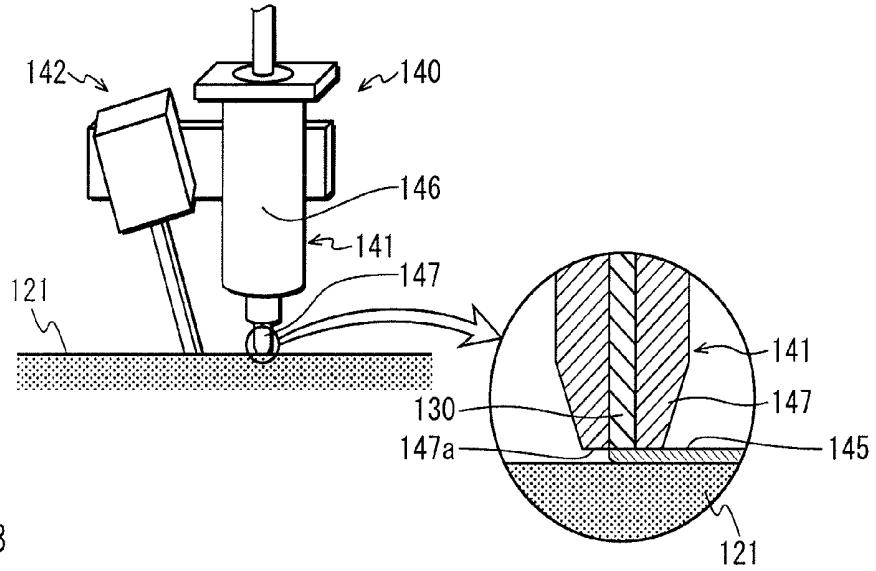

FIG. 10B

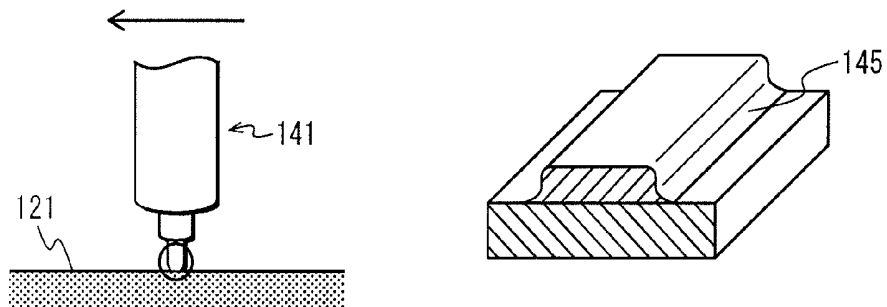

FIG. 10C

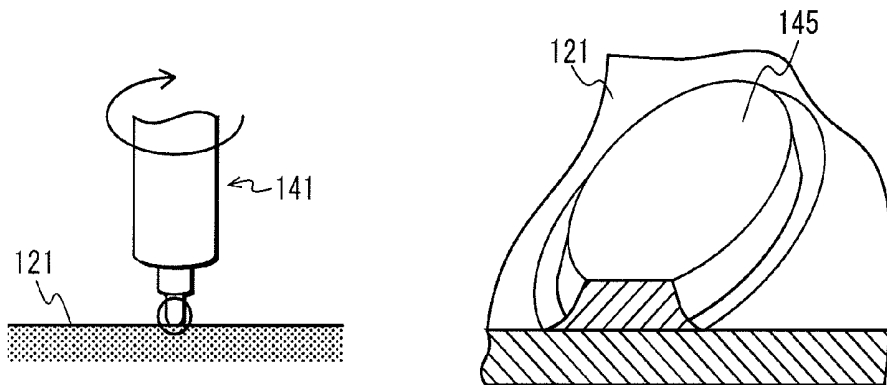

FIG. 11A

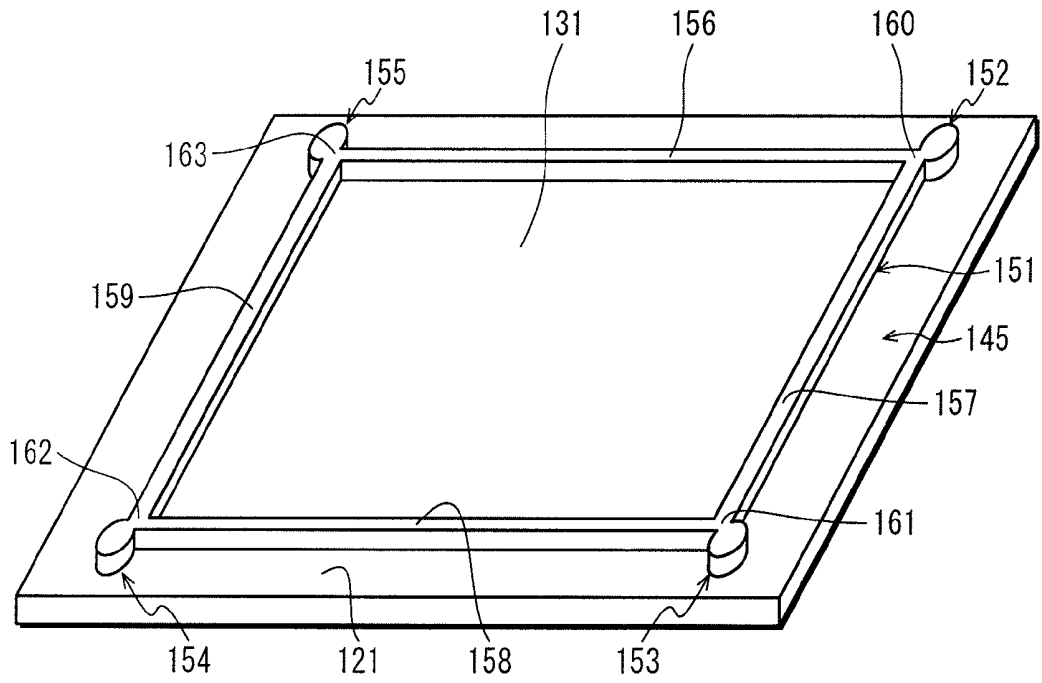

FIG. 11B

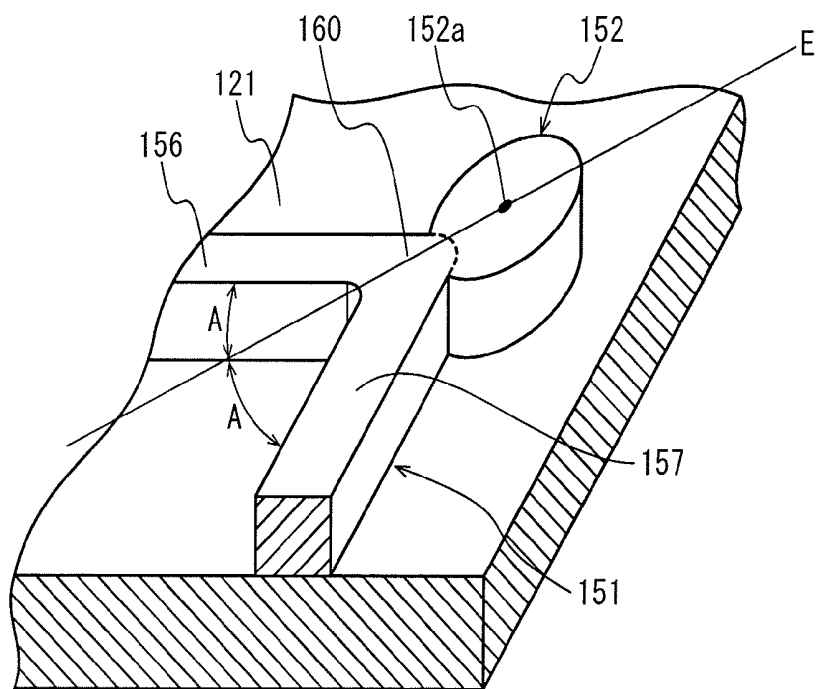

FIG. 12A

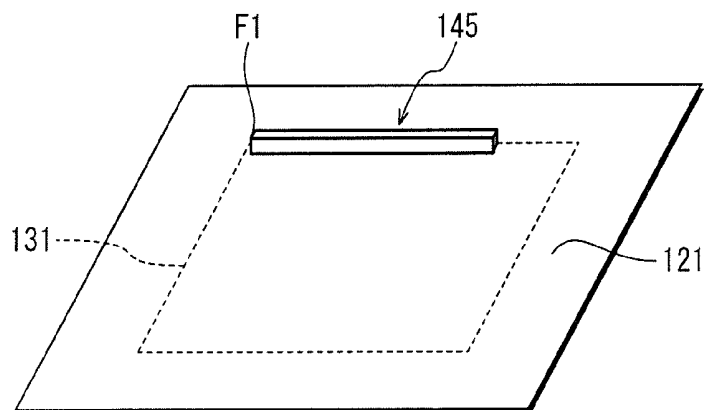

FIG. 12B

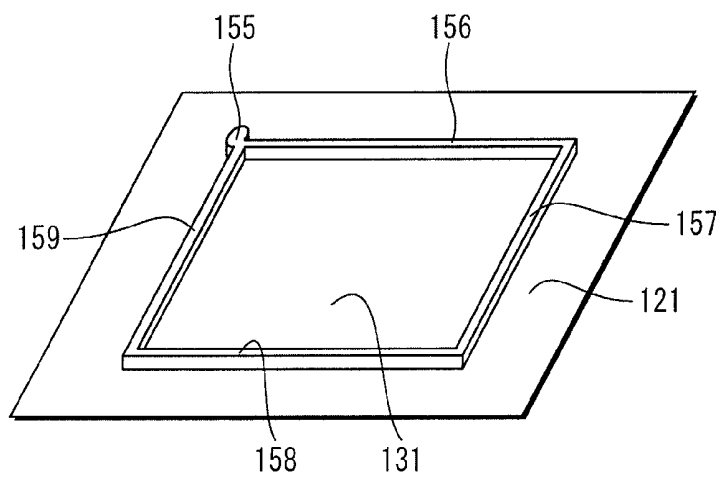
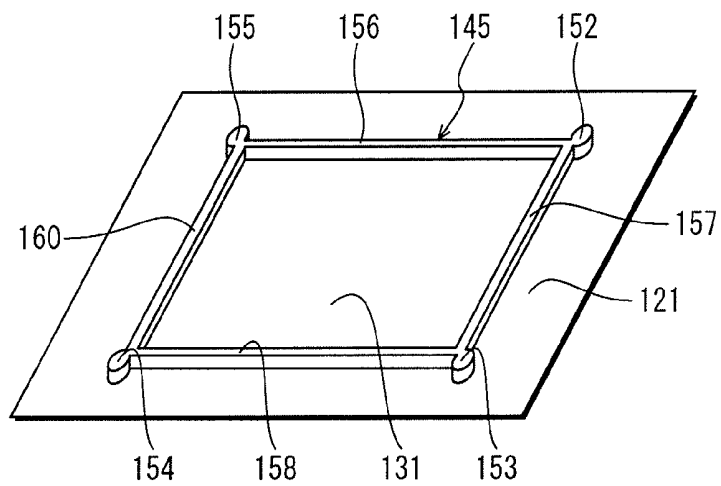

FIG. 12C





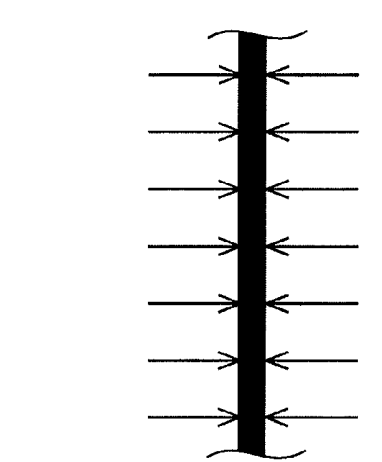
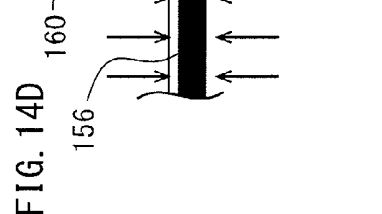
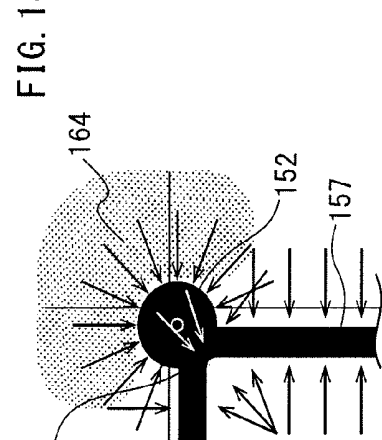
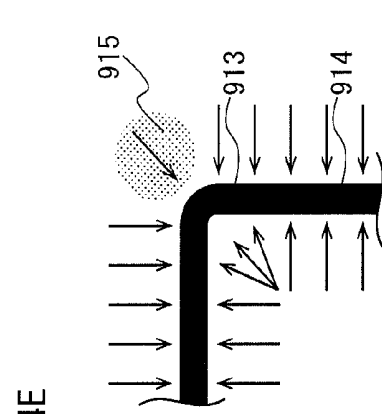
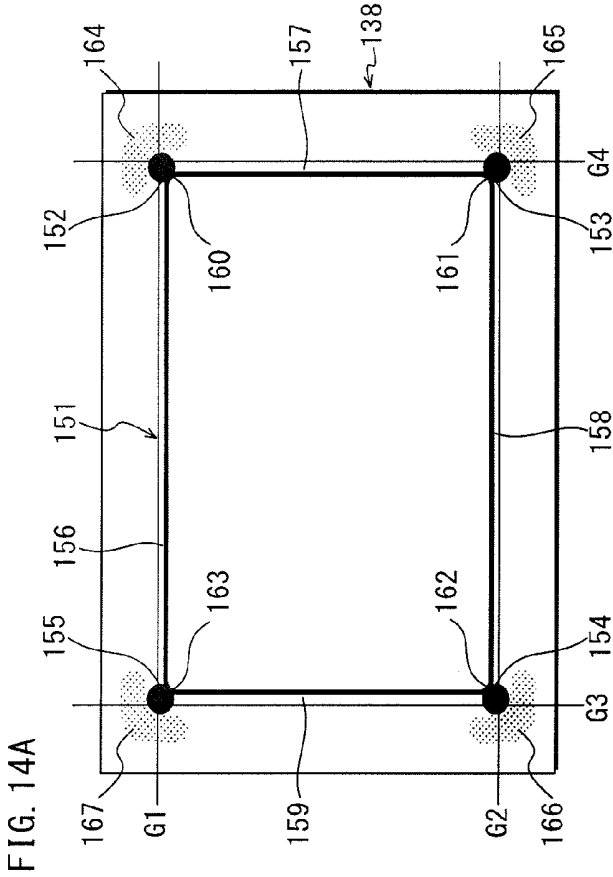
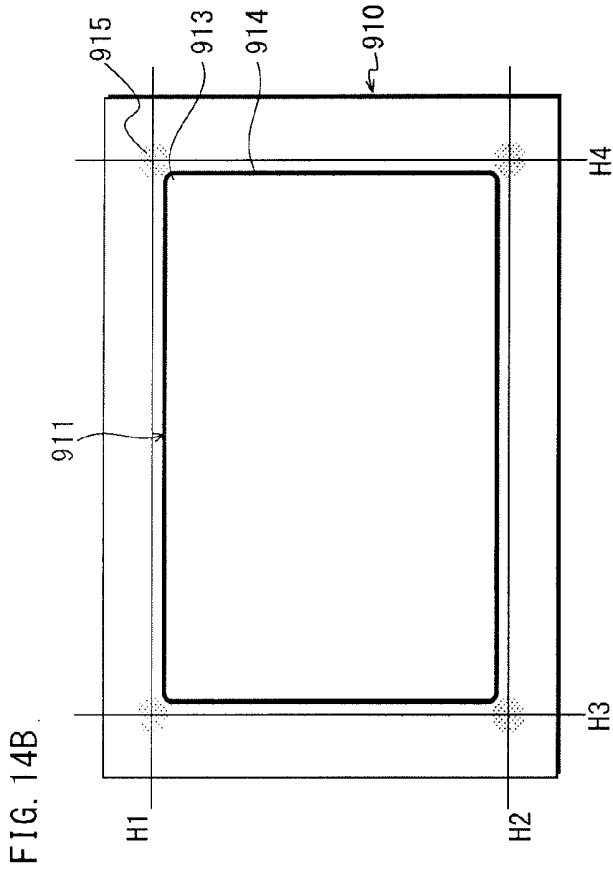

FIG. 15

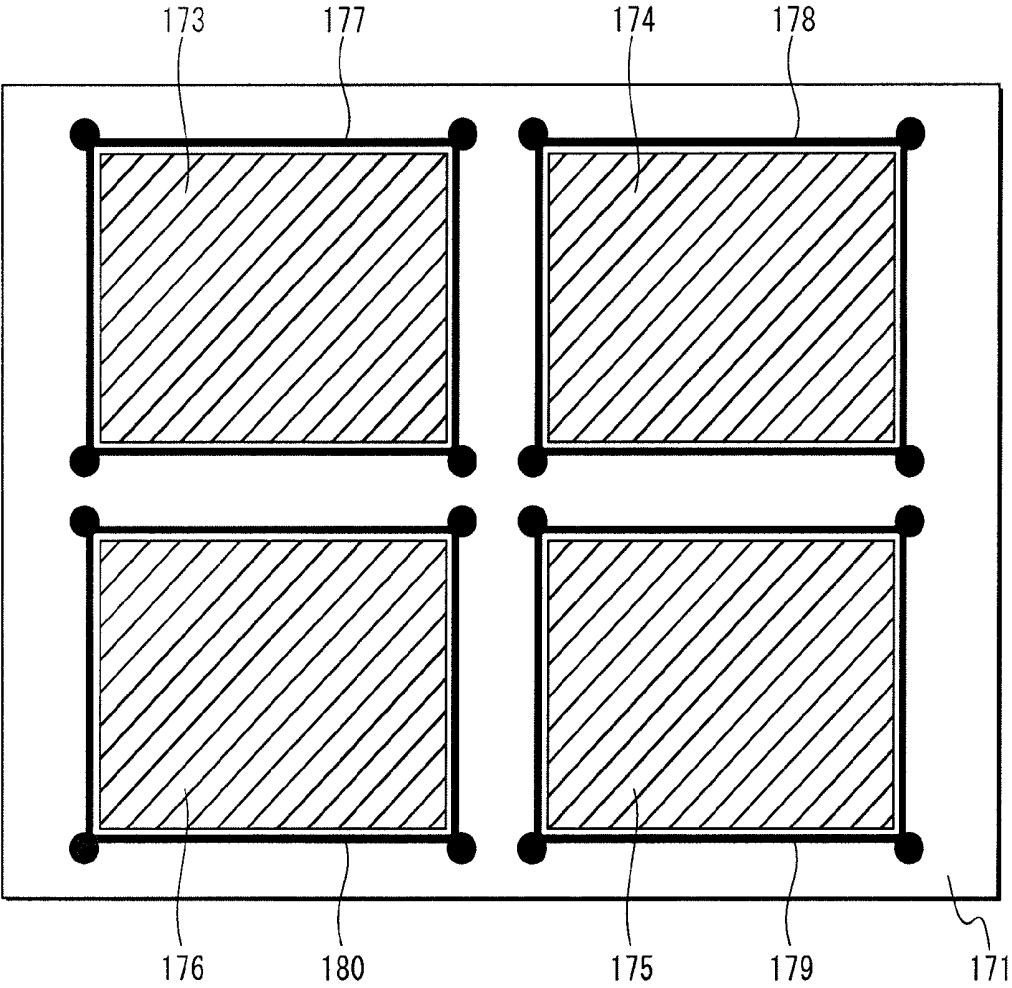



FIG. 17A

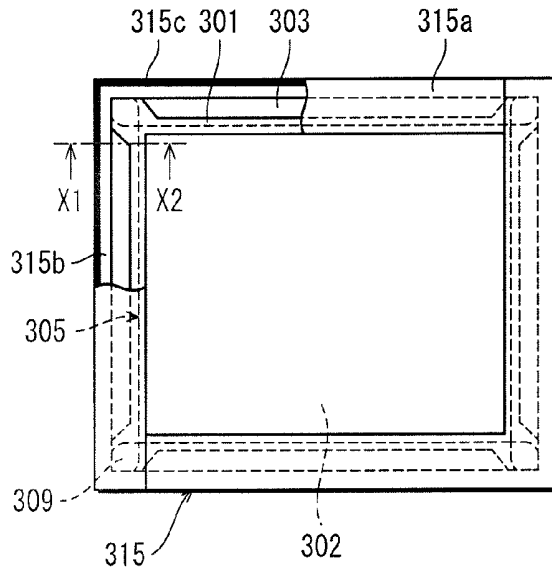

FIG. 17B

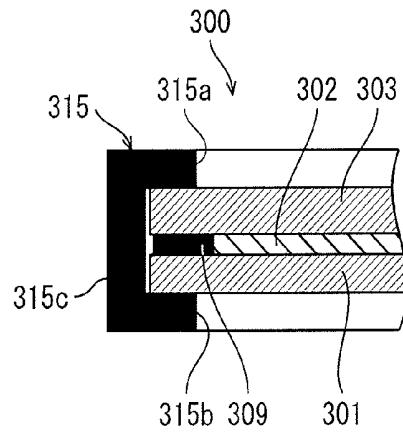

FIG. 17C

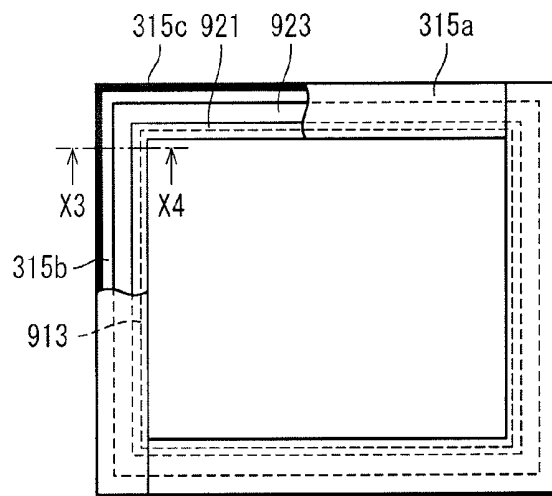

FIG. 17D

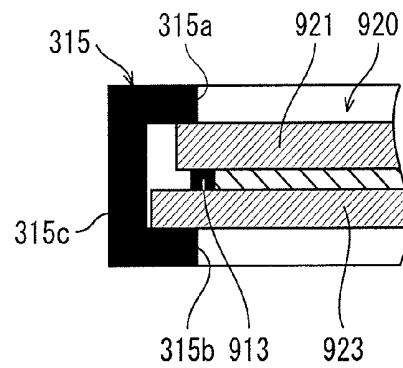

FIG. 18A

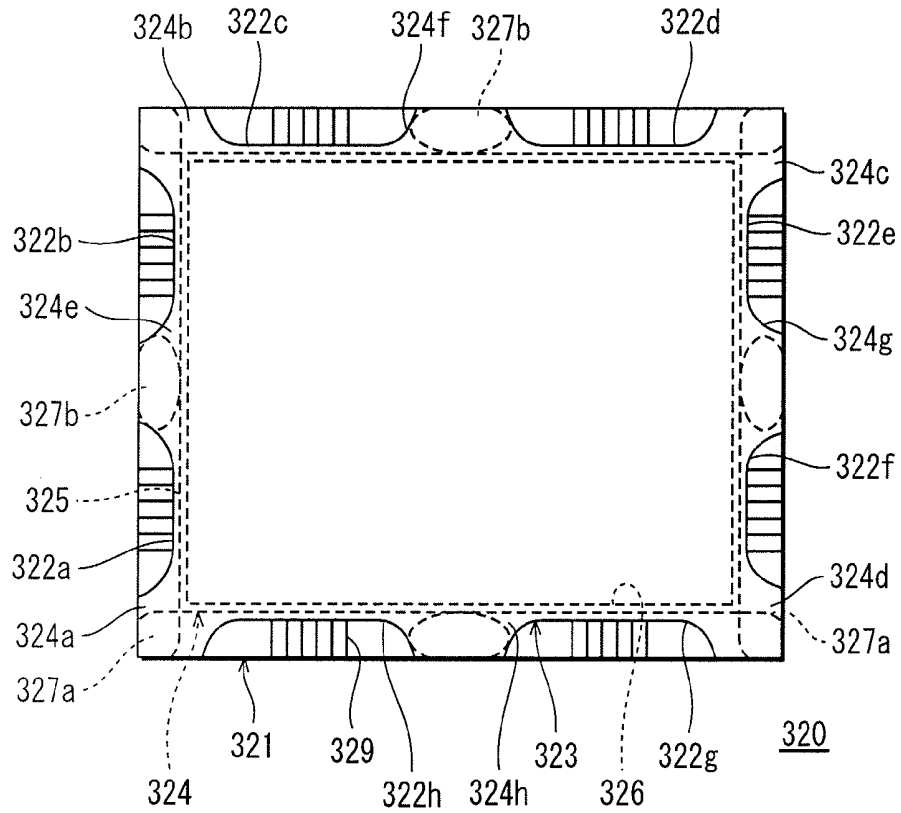

FIG. 18B

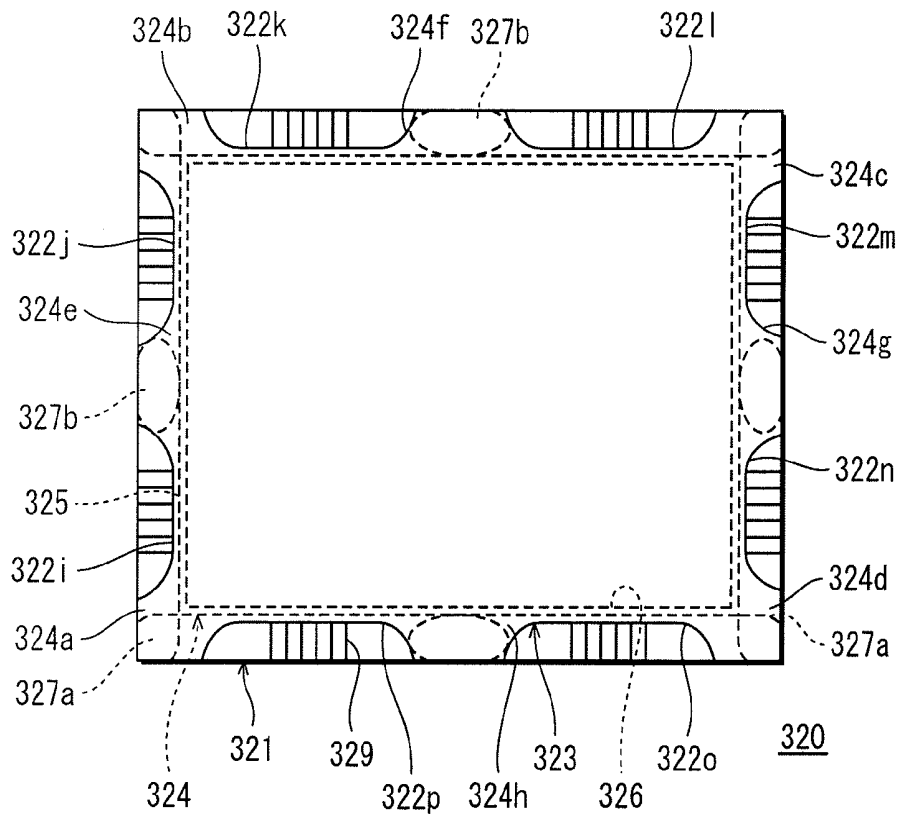

FIG. 19

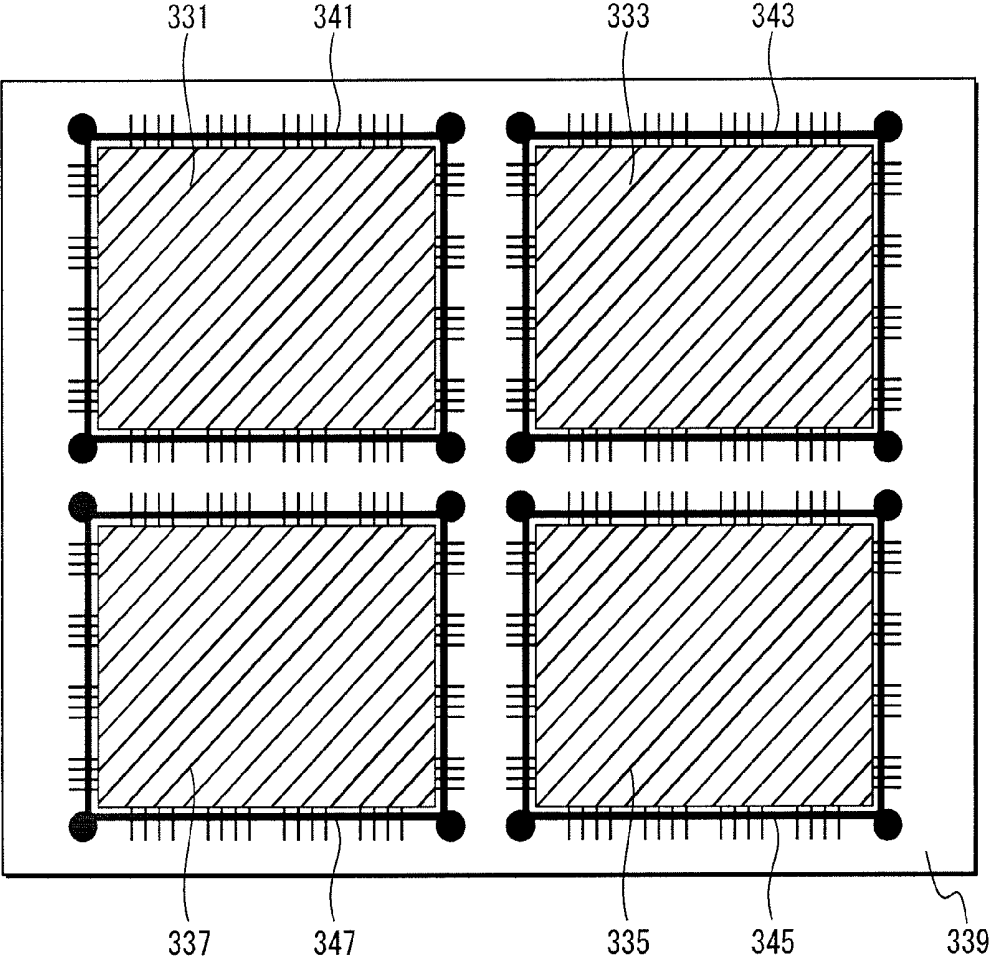

FIG. 20A

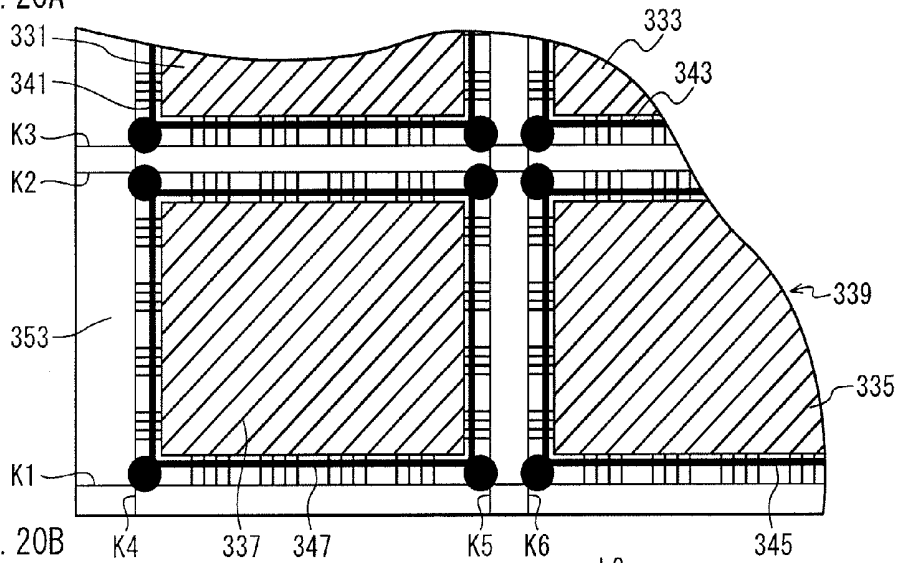

FIG. 20B

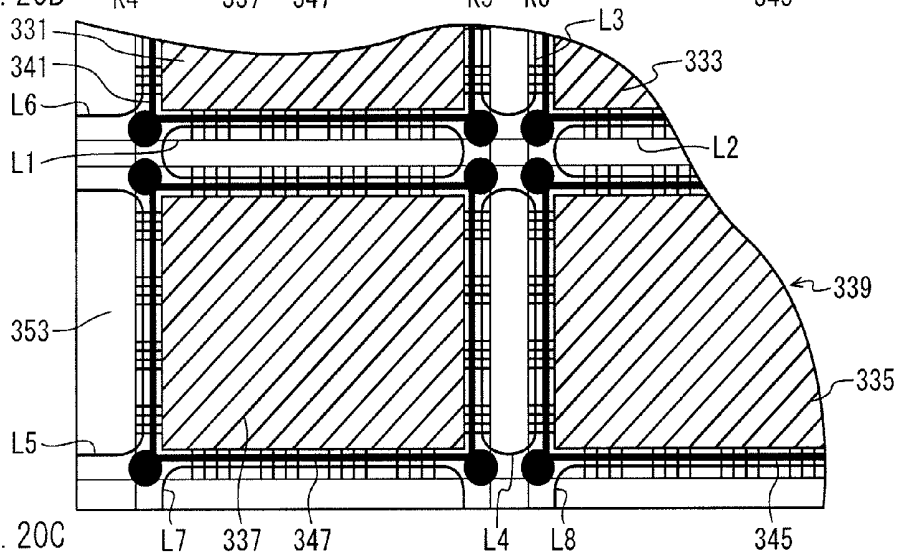

FIG. 20C

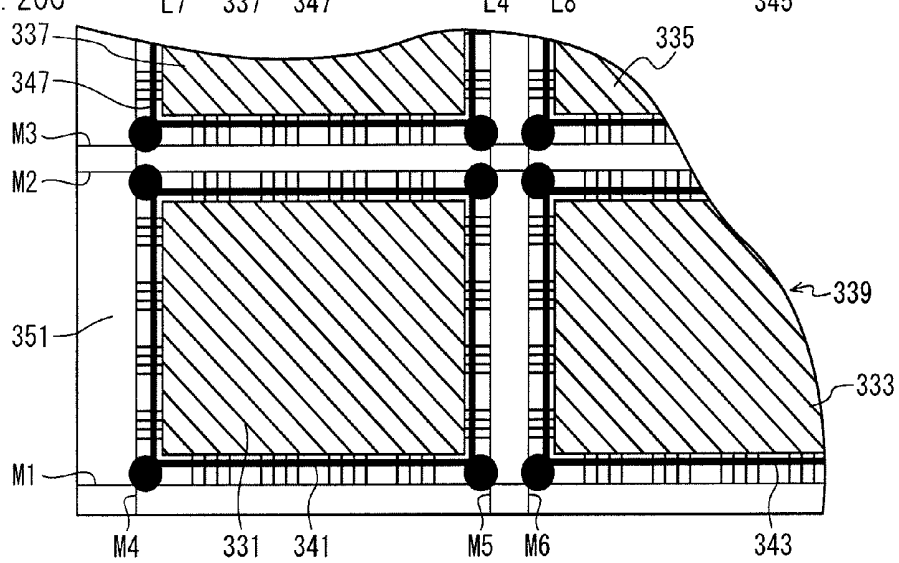

FIG. 21A

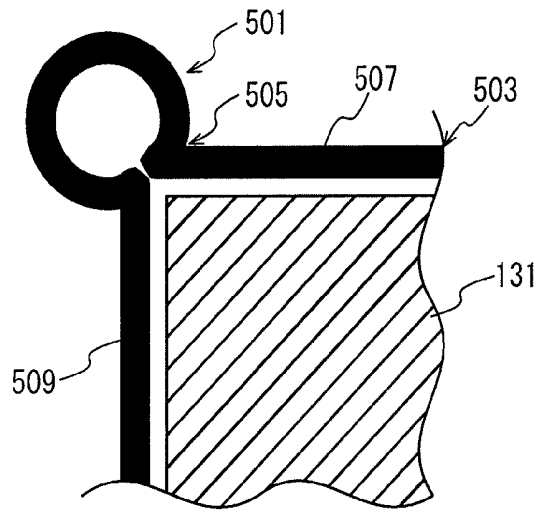

FIG. 21B

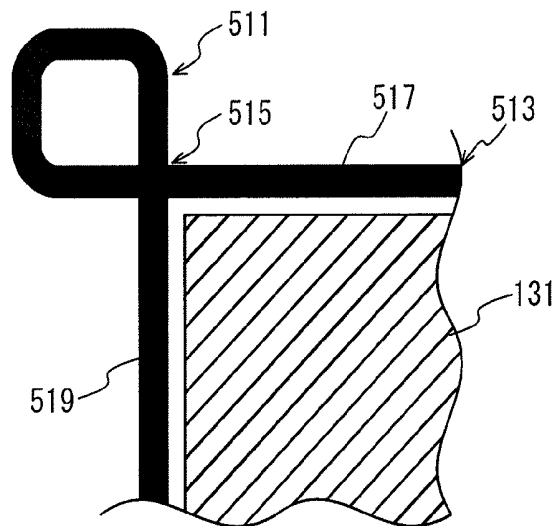
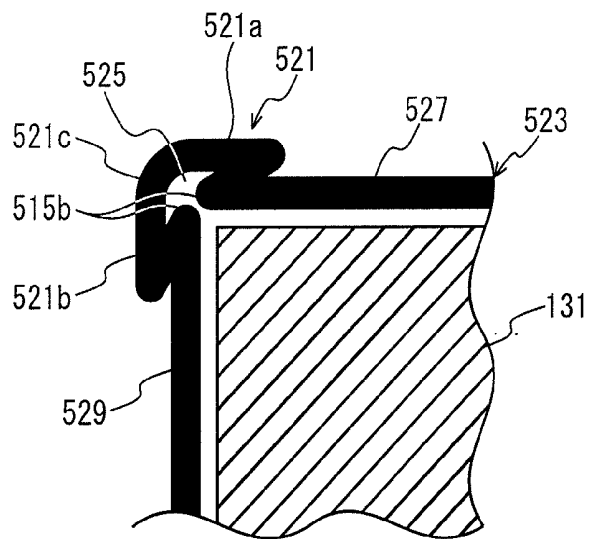
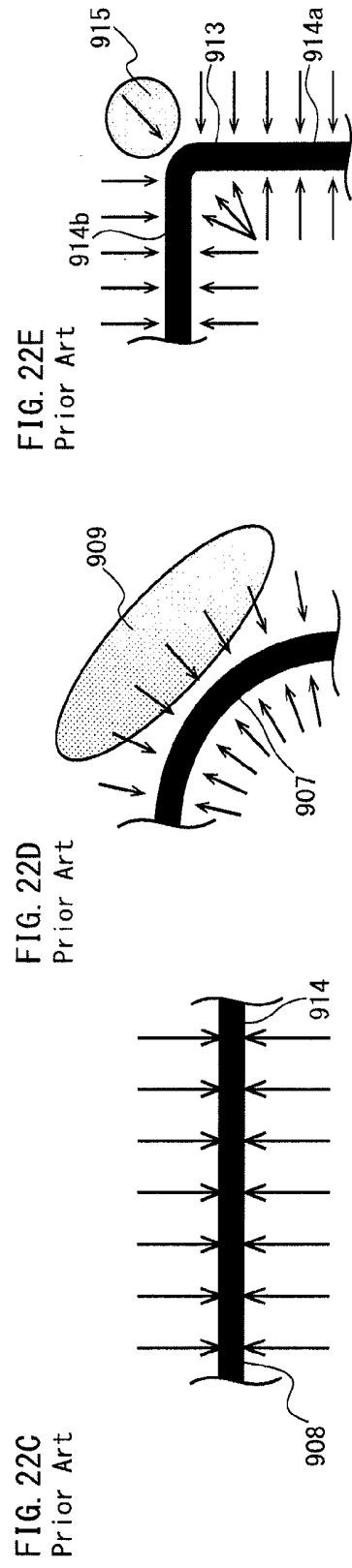
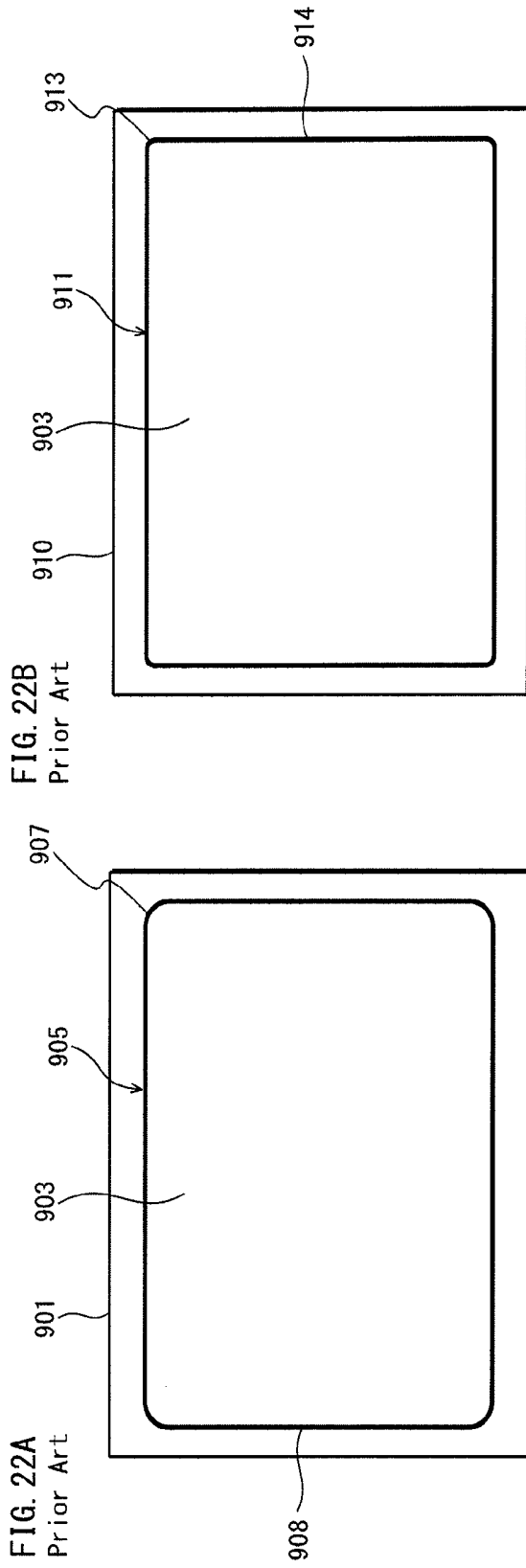

FIG. 21C





## DISPLAY PANEL AND DISPLAY PANEL MANUFACTURING METHOD

### TECHNICAL FIELD

[0001] The present disclosure pertains to a display panel and a manufacturing method therefor, where a display region provided between two opposing substrates is sealed by a sealing member that surrounds the display region while also being provided between the substrates.

### BACKGROUND ART

[0002] An organic electroluminescence (hereinafter, EL) element is a type of self-illuminating element and, as such, requires no backlight while providing a wide viewing angle, is easily applicable to thinning and power consumption reduction, and has a high response speed, among other merits. An organic electroluminescence panel (hereinafter, EL panel) in which such EL elements are arranged has come to attention as a next-generation display panel serving as a replacement for liquid crystal devices.

[0003] Typically, an organic EL element has an organic EL laminate structure in which an organic material layer that includes a lower electrode and a light-emitting layer is sequentially layered on a substrate with an upper electrode.

[0004] The material used for the organic EL laminate structure is typically unstable and highly active, prone to reacting with water and oxygen in the atmosphere. These reactions with atmospheric water and oxygen are a cause of deterioration in the properties of the organic EL element. As such, sealing the organic EL element of the organic EL display panel from the atmosphere is indispensable.

[0005] A sealing member is provided in order to prevent deterioration due to the infiltration of water and oxygen from the outside atmosphere into the light-emitting element of the organic EL element within a display region.

[0006] The display region is sealed by applying a paste (e.g., a glass paste) that includes a sealing material (e.g., frit glass) so as to surround the display region (i.e., a planned formation region for the element) on one of two substrates, drying and joining to the other substrate, and then fusing (i.e., baking) the sealing material. Upon baking, the sealing material is termed a sealing member.

[0007] The display panel is obtained by cutting away peripheral areas of an intermediate panel produced by joining the two substrates (i.e., sealing with the sealing member).

### CITATION LIST

#### Patent Literature

[Patent Literature 1]

[0008] Japanese Patent Application Publication No. H10-116560

### SUMMARY OF INVENTION

#### Technical Problem

[0009] In recent years, demand has intensified for distance between the display region and the display panel periphery to be reduced, that is, for reduction in the width of the frame. Reducing the occurrence of breakage and so on in the sealing member and constraining decreases in manufacturing efficiency are also beneficial.

[0010] In consideration of the above-described problem, the present invention aims to provide a display panel and a manufacturing method therefor, enabling a reduction in the width of the frame while also maintaining manufacturing efficiency.

#### Solution to Problem

[0011] In order to address this problem, a display panel pertaining to an aspect of the present disclosure comprises: a first substrate; a second substrate arranged opposite the first substrate; a plurality of electroluminescence elements disposed between the first substrate and the second substrate; and a sealing member provided between the first substrate and the second substrate, sealing the electroluminescence elements, wherein the sealing member includes a rectangular frame formed along a perimeter of the electroluminescence elements, and a reinforced portion protruding outward from a corner portion of the rectangular frame, the reinforced portion includes a first side face cut so as to be flush with at least one corner side face of the first substrate, and a second side face cut so as to be flush with a corresponding corner side face of the second substrate, and the first side face and the second side face are coplanar.

[0012] Also, a manufacturing method for a display panel pertaining to another aspect of the disclosure comprises: forming a plurality of electroluminescence elements within a central region of a first substrate; using a sealing material to provide, on one of the first substrate and a second substrate, a rectangular frame surrounding a region corresponding to the central region and a reinforced portion protruding outward from a corner portion of the rectangular frame; sealing the electroluminescence elements by joining the first substrate and the second substrate with the sealing material interposed therebetween; and cutting the first substrate and the second substrate, wherein cutting the first substrate and the second substrate involves cutting the reinforced portion while overlapping with respective corner portions of the first substrate and the second substrate, as viewed from a joining direction.

#### Advantageous Effects of Invention

[0013] The display panel pertaining to one aspect of the present disclosure has a reinforced portion protruding outward from a corner portion of a rectangular frame, such that residual strain, produced during heating in the manufacturing process of the display panel, mainly occurs in regions outside the reinforced portion. The reinforced portion also includes a side face cut so as to be aligned with a side face of a corner portion of at least one of a first substrate and a second substrate. Thus, cutting is performed closer to the center of the display panel than a region where the residual strain occurs. In comparison to cutting inside the region where the residual strain occurs, this approach better prevents fracturing of the first and second substrates during the cutting process, thereby improving manufacturing efficiency (i.e., yield optimization).

[0014] Accordingly, the reinforced portions protrude outward from the corner portions of the rectangular frame. However, given that the reinforced portions include a side face cut so as to be aligned with at least one side face of a corner portion of a first substrate and a corner portion of a second substrate, cutting is performed across the reinforced portions. As a result, the amount of protrusion from the corner portions

of the rectangular frame is reduced, thereby satisfying the demand for reduction in the width of the frame.

[0015] As described above, the presence of the reinforced portions protruding outward from the corner portions of the rectangular frame enables fractures of the first and second substrates due to residual strain to be prevented at cutting time, and enables the radius of the corner portions to be reduced (i.e., provides corners closer to right angles) so as to respond to demand for reduction in the width of the frame.

#### BRIEF DESCRIPTION OF DRAWINGS

[0016] FIG. 1 is a partial cross-sectional diagram schematically illustrating key portions of a display panel pertaining to Embodiment 1.

[0017] FIG. 2 is a plan view of an EL substrate.

[0018] FIG. 3 is a cross-section of FIG. 2 taken along line A1-A2.

[0019] FIG. 4 is a cross-section of FIG. 2 taken along line B1-B2.

[0020] FIG. 5 is a plan view of a colour filter substrate.

[0021] FIG. 6 is a cross-section of FIG. 5 taken along line C1-C2.

[0022] FIG. 7 is a cross-section of FIG. 5 taken along line D1-D2.

[0023] FIGS. 8A-8D illustrate a colour filter process, where FIG. 8A represents a glass substrate prior to frit paste application, FIG. 8B represents the glass substrate after frit paste application, FIG. 8C represents frit paste baking, and FIG. 8D represents a baked glass substrate.

[0024] FIGS. 9A-9D illustrate a conjoining process, where FIG. 9A illustrates the colour filter substrate and the EL substrate prior to joining, FIG. 9B illustrates the joined colour filter and EL substrates, FIG. 9C illustrates a resin curing process, and FIG. 9D illustrates the EL unification process.

[0025] FIGS. 10A-10C illustrate a dispenser device, where FIG. 10A is a schematic illustration, FIG. 10B is a perspective view of the frit paste after application when the dispenser device has advanced linearly, and FIG. 10C is a perspective view of the frit paste after application when the dispenser device has advanced rotationally.

[0026] FIGS. 11A and 11B are schematic diagrams of the frit paste as applied, where FIG. 11A is a perspective view and FIG. 11B is a magnified view of a reinforced portion.

[0027] FIGS. 12A-12C illustrate a frit paste application method, where FIG. 12A illustrates the beginning of application, FIG. 12B illustrates a stage where one reinforced portion has been formed, and FIG. 12C illustrates the completed frit paste application.

[0028] FIG. 13 illustrates a cutting process.

[0029] FIGS. 14A-14E illustrate the relationship between strain positions and scribed lines, where FIG. 14A illustrates an intermediate panel pertaining to an Embodiment, FIG. 14B illustrates a conventional intermediate panel, FIG. 14C is a magnified view of portions common to FIGS. 14A and 14B, FIG. 14D is a magnified view of a corner portion in FIG. 14A, and FIG. 14E is a magnified view of a corner portion in FIG. 14B.

[0030] FIG. 15 illustrates an example of frit paste application in a multipanel method for display panels.

[0031] FIGS. 16A and 16B illustrate an example pertaining to Embodiment 2 in which the display panel has substrates of different dimensions, FIG. 16A being a plan view and FIG. 16B being a magnified view of a corner.

[0032] FIGS. 17A-17D illustrate the use of fixing material to join the EL substrate to the colour filter substrate, where FIG. 17A illustrates a case where the display panel pertaining to Embodiment 2 is used, FIG. 17B is an expanded view of a cross-section of FIG. 17A taken along line X1-X2, FIG. 17C illustrates a case where a conventional display panel is used, and FIG. 17D is an expanded view of a cross-section of FIG. 17C taken along line X3-X4.

[0033] FIGS. 18A and 18B illustrate a variation of Embodiment 2.

[0034] FIG. 19 illustrates a large intermediate panel used for a multi-panel method applied to the display panel.

[0035] FIGS. 20A-20C illustrate the cutting of the display panels from the large intermediate panel, where FIGS. 20A and 20B show the large intermediate panel as seen from the colour filter substrate, and FIG. 20C shows the large intermediate panel as seen from the EL substrate.

[0036] FIGS. 21A-21C illustrate Examples 1-3 of the reinforced portions, where FIG. 21A pertains to Example 1, FIG. 21B pertains to Example 2, and FIG. 21C pertains to Example 3.

[0037] FIGS. 22A-22E illustrate the intermediate panel prior to cutting according to conventional technology, where FIG. 22A illustrates a case where the radius of the corner portions of the rectangular sealing member has been increased, FIG. 22B illustrates a case where the radius of the corner portions of the rectangular sealing member has been decreased, FIG. 22C is a magnified view of the common edge portions from FIGS. 22A and 22B, FIG. 22D is a magnified view of a corner portion from FIG. 22A, and FIG. 22E is a magnified view of a corner portion from FIG. 22B.

#### DESCRIPTION OF EMBODIMENTS

[0038] [Overview of Embodiments]

[0039] In one aspect, a display panel comprises: a first substrate; a second substrate arranged opposite the first substrate; a plurality of electroluminescence elements disposed between the first substrate and the second substrate; and a sealing member provided between the first substrate and the second substrate, sealing the electroluminescence elements, wherein the sealing member includes a rectangular frame formed along a perimeter of the electroluminescence elements, and a reinforced portion protruding outward from a corner portion of the rectangular frame, the reinforced portion includes a first side face cut so as to be flush with at least one corner side face of the first substrate, and a second side face cut so as to be flush with a corresponding corner side face of the second substrate, and the first side face and the second side face are coplanar.

[0040] Also, the first substrate and the second substrate have corresponding side faces. Accordingly, the reinforced portions, the first substrate, and the second substrate can be cut simultaneously, thereby improving manufacturing efficiency.

[0041] In another aspect, the electroluminescence elements are mounted on the first substrate, and a side face of the second substrate is indented toward a second substrate center with respect to a line extending from the corner side face of the second substrate. Accordingly, the reinforced portions of the sealing member remain between the first and second substrates, thereby enabling the display panel strength to be preserved.

[0042] In a further aspect, an indented portion of the side face of the second substrate is closer to the second substrate

center than a side face of the first substrate is to the second substrate center. Accordingly, an auxiliary electrode or similar may be arranged in a region of the first substrate that does not face the second substrate.

**[0043]** In an additional aspect, the sealing member is frit glass. Accordingly, when frit glass is used as the sealing member material, for instance, the material greatly differs in elasticity from the substrate, and more stress is applied between the substrate and the frit glass when the frit glass hardens and contracts than when resin material is used for the sealing member. In contrast, the above-described configuration enables the frit glass to be used as the sealing member.

**[0044]** In an alternate aspect, the sealing member further includes a reinforced middle portion protruding outward from an inter-corner portion of the rectangular frame. Accordingly, when, for example, the peripheral portions of the first and second substrates are fixed by the fixing material, deformation of the substrates is reduced between the corner portions thereof.

**[0045]** Also, in one aspect, a manufacturing method for a display panel comprises: forming a plurality of electroluminescence elements within a central region of a first substrate; using a sealing material to provide, on one of the first substrate and a second substrate, a rectangular frame surrounding a region corresponding to the central region and a reinforced portion protruding outward from a corner portion of the rectangular frame; sealing the electroluminescence elements by joining the first substrate and the second substrate with the sealing material interposed therebetween; and cutting the first substrate and the second substrate, wherein cutting the first substrate and the second substrate involves cutting the reinforced portion while overlapping with respective corner portions of the first substrate and the second substrate, as viewed from a joining direction. Accordingly, the display panel is able to satisfy the aims of manufacturing efficiency as well as reduction in the width of the frame.

**[0046]** In another aspect, the reinforced portion is cut while simultaneously overlapping with both of the respective corner portions of the first substrate and the second substrate, as viewed from the joining direction, such that overlapping portions are flush. Accordingly, the display panel is manufactured efficiently.

**[0047]** In yet another aspect, the second substrate is cut such that a side face thereof is indented toward a second substrate center with respect to a line extending from the corner portion. Accordingly, the reinforced portions of the sealing member remain between the first and second substrates, thereby enabling the display panel strength to be preserved.

## EMBODIMENTS

**[0048]** The following describes a display panel pertaining to Embodiments of the disclosure as well as a manufacturing method therefor, with reference to the accompanying drawings. In the Embodiments, the materials and dimensions listed as being used are given as beneficial examples. No limitation is intended thereto. Also, appropriate variations may be made, provided that no deviation from the technical intent of the disclosure arises. Further, the Embodiments may be freely combined provided that no contradiction results.

## Embodiment 1

### 1. Configuration

#### (1) Overall Configuration

**[0049]** FIG. 1 is a partial cross-sectional diagram schematically illustrating key portions of a display panel **10** pertaining to Embodiment 1.

**[0050]** As shown, the display panel **10** includes an EL substrate **11** and a colour filter (hereinafter also CF) substrate **12**, as well as a sealing resin layer **13** interposed between the EL substrate **11** and the CF substrate **12**.

**[0051]** The sealing resin layer **13** is provided and applied in liquid form and then cured, with the aims of conjoining the EL substrate **11** and the CF substrate **12** and of protecting the EL substrate **11** from infiltration by water and gas from outside the display panel **10**. However, the sealing resin layer **13** is not strictly necessary and may be omitted from the configuration.

**[0052]** Light exits the display panel **10** from the top or front. However, with respect to FIG. 1, light exits from the bottom as drawn.

#### (2) EL Substrate

**[0053]** The EL substrate **11** is made up of a substrate, an inter-layer insulation film, an anode, a bank, a light-emitting layer, and so on.

**[0054]** FIG. 2 is a plan view of the EL substrate. FIG. 3 is a cross-section of FIG. 2 taken along line A1-A2. FIG. 4 is another cross-section of FIG. 2, taken along line B1-B2.

**[0055]** Here, the side of the EL substrate **11** that is joined to the CF substrate **12** is the top face or front (the lower side as illustrated in FIG. 1).

**[0056]** The EL substrate **11** includes a substrate (**111**) having a plurality of pixels **30** disposed thereon in rows and columns. Here, each of the pixels **30** is made up of three light-emitting elements **31(R)**, **31(G)**, and **31(B)** (in three colours R, G, and B). The light-emitting elements are referred to in generality, irrespective of colour, with the reference sign **31**. The pixels **30** are arranged as a matrix disposed in a display region **131**.

**[0057]** Here, the substrate (**111**) corresponds to the first substrate of the disclosure, and the light-emitting elements **31** correspond to the electroluminescence elements of the disclosure.

**[0058]** The display region **131** represents a region in which the EL substrate **11** and the CF substrate **12** are joined, formed by the pixels **30** and colour filters **122** and displaying an image, and includes a planned formation region for the pixels **30** on the EL substrate (i.e., a TFT substrate) and a planned formation region for the colour filters **122** on the CF substrate (i.e., a glass substrate).

**[0059]** Here, each of the light-emitting elements **31** is formed longitudinally, and the three light-emitting elements **31(R)**, **31(G)**, and **31(B)** neighbour each other with respect to the shorter dimension. As such, each of the pixels **30** is formed so as to be substantially square as seen in the plan view (see FIG. 2). The plurality of pixels **30** form an EL element **30a**.

**[0060]** The following description is made with primary reference to FIGS. 2-4.

[0061] The substrate is a TFT substrate **111**. An inter-layer insulation film **112** is formed over the top face of the TFT substrate **111**.

[0062] Anodes **113a** are disposed in correspondence with light-emitting element **31** units on the top face of the inter-layer insulation film **112**. The anodes **113a** are formed longitudinally, similar to the light-emitting element **31** as seen in the plan view. As shown in FIGS. **3** and **4**, in addition to the anodes **113a**, auxiliary electrodes **113b** are also formed on the top face of the inter-layer insulation film **112**, between the pixels **30**.

[0063] A bank **114** is formed between the anodes **113a**, as well as between the anodes **113a** and the auxiliary electrodes **113b**. The bank **114** is formed so as to extend from an area on the inter-layer insulation film **112** where the anodes **113a** and the auxiliary electrodes **113b** are not formed, and between the anodes **113a** and the auxiliary electrodes **113b**, so as to protrude upward.

[0064] A light-emitting layer **115** (here, an organic light-emitting layer) of a predetermined colour is layered over the top face of the anodes **113a** in each region defined by (i.e., surrounded by) the bank **114**.

[0065] Here, the predetermined colour is one of blue, green, and red, though other colours such as yellow may also be included. In the drawings, the blue light-emitting layer is denoted **115 (B)**, the green light-emitting layer is denoted **115 (G)**, and the red light-emitting layer is denoted **115 (R)**. The reference sign **115** is also used to refer to the light-emitting layers in generality, irrespective of colour.

[0066] A cathode **116** and a sealing layer **117** are respectively formed over the surfaces of each organic light-emitting layer **115** so as to extend beyond the region defined by the bank **114** into neighbouring organic light-emitting layers **115**, and over the top faces of the auxiliary electrodes **113b**. The sealing layer **117** serves to prevent the organic light-emitting layers **115** from being exposed to water or to air.

### (3) CF Substrate

[0067] FIG. **5** is a plan view of the CF substrate. FIG. **6** is a cross-section of FIG. **5** taken along line C1-C2. FIG. **7** is another cross-section of FIG. **5**, taken along line D1-D2.

[0068] Here, the side of the CF substrate **12** that is joined to the EL substrate **11** is the top face or surface (the upper side as illustrated in FIG. **1**).

[0069] The CF substrate **12** includes a substrate **121**, colour filters **122**, and so on. The substrate **121** corresponds to the second substrate of the disclosure.

[0070] As shown in FIG. **5**, the colour filters **122** are formed longitudinally, similar to the light-emitting elements **31** shown in the plan view of FIG. **2**.

[0071] The following description is made with primary reference to FIGS. **6** and **7**.

[0072] The substrate **121** is a front-face substrate of the display panel **10** and is made from an optically transmissive material. Colour filters **122 (B)**, **122(G)**, and **122(R)** are formed on the top face of the substrate **121** in correspondence with the organic light-emitting layers **115 (B)**, **115 (G)**, and **115 (R)** of the EL substrate **11**. Reference sign **122** is also used to refer to the colour filters in generality, irrespective of colour.

[0073] A black matrix **123** (hereinafter, BM) is formed between the colour filters **122** on the top face of the substrate **121**. As shown in FIGS. **6** and **7**, each of the colour filters **122**

is formed so as to extend partially into a peripheral region of the neighbouring BM **123** on each side.

[0074] The BM **123** is a black layer that prevents the incidence of light from the outside and of light reflected back from the display surface of the display panel **10**, and is intended to improve the display contrast. As shown in FIG. **1**, the BM **123** is formed in correspondence with (i.e., opposite) the bank **114** on the EL substrate **11**.

[0075] The display region having the colour filters **122** and the BM **123** formed therein is a colour filter **122a**.

### (4) Periphery

[0076] The display panel **10** is provided with sealant **134** and a sealing member **133** at the periphery thereof. Specifically, the sealant **134** and the sealing member **133** are provided so as to surround the periphery of the display region **131**, the sealing member **133** being disposed outside the sealant **134**. The sealant **134** seals the interior between the joined EL substrate **11** and CF substrate **12**.

[0077] In the present description, the sealing member refers to a sealing material that is fused and unified with the EL substrate **11** and with the CF substrate **12** so as to seal the display region **131**, and also uses reference sign **133**.

## 2. Manufacturing Method

[0078] The following example of a manufacturing method of the display panel **10** includes an EL preparation process (1) of preparing the EL substrate **11a**, a colour filter preparation process (2) of preparing the CF substrate **12a** to which the sealing material is applied, a conjoining process (3) of conjoining the prepared EL substrate **11a** and the prepared CF substrate **12a**, and a cutting process (4) of cutting the perimeter of an intermediate panel **138**. Here, a paste that includes the sealing material is used. Specifically, the sealing material is a glass frit, and the paste is a frit paste.

### (1) EL Preparation Process

[0079] The EL preparation process serves to prepare the EL substrate **11a**. Specifically, the light-emitting elements **31** (i.e., EL element **30a**) are formed on the substrate. Given that this process involves forming light-emitting elements using well-known conventional technology, the explanation thereof is abridged. The EL substrate **11** of the display panel **10** has had peripheral portions (i.e., unneeded portions) of the EL substrate **11a** cut away.

### (2) Colour Filter Process

[0080] The colour filter preparation process includes an application process of applying the frit paste to the substrate, a unification process of unifying the applied frit paste (more accurately, the frit glass in the frit paste) with the substrate, and a colour filter formation process of forming the colour filters **122a** on the substrate. Here, the substrate having the colour filters **122a** formed thereon is the CF substrate **12a**. The CF substrate **12** of the display panel **10** has had peripheral portions (i.e., unneeded portions) of CF substrate **12a** cut away.

[0081] The following describes the process in detail, with reference to the drawings. This process includes processes of unifying the frit glass with the EL substrate and with the CF substrate. As such, the processes are illustrated on separate

drawings, one indicating a CF unification process for the CF substrate and one indicating an EL unification process for the EL substrate.

**[0082]** FIGS. 8A-8D illustrate the colour filter process. FIG. 8A represents the glass substrate prior to frit paste application. FIG. 8B represents the glass substrate after frit paste application. FIG. 8C represents the frit paste baking. FIG. 8D represents the baked glass substrate.

**[0083]** Each of FIGS. 8A-8D includes two drawings on the left-hand and right-hand sides, showing the same part of the process. The left-hand side is a perspective view diagram and the right-hand side is a cross-sectional diagram.

#### (a) Application Process

**[0084]** The glass substrate 121 is prepared as shown in FIG. 8A, then the frit paste 130 is applied to the top face of the glass substrate 121 as shown in FIG. 8B.

**[0085]** The frit paste 130 is applied using a dispenser method so as to surround the perimeter of the display region 131 (i.e., the planned formation region for the colour filter 122a).

#### (b) CF Unification Process

**[0086]** The CF unification process includes a dry process of removing the solvent from the frit paste 145 and a baking process of removing the binder and so on from the frit paste 145.

**[0087]** As shown in FIG. 8C, the baking process is performed using a laser 132. The binder and so on are removed and the frit glass (i.e., glass powder) in the frit paste 145 is fused. Thus, the glass substrate 121 is unified with the frit glass as shown in FIG. 8D. The sealing material 133 is produced once the frit glass is baked and unified with the glass substrate 121.

#### (c) Colour Filter Formation Process

**[0088]** The colour filter formation process involves forming the colour filter 122a on the display region 131 of the glass substrate 121 having the sealing material 133 formed thereon. Given that this process involves using well-known conventional technology, the explanation thereof is abridged. This completes the CF substrate 12a.

#### (3) Conjoining Process

**[0089]** The conjoining process includes a sealant application process of applying the sealant to the CF substrate 12a, a resin material application process of applying a resin material for sealing to the colour filter 122a on the CF substrate 12a, a joining process of joining the EL substrate 11a to the CF substrate 12a having the sealant and the resin material applied thereto, a decompression process of having the joined EL substrate 11a and CF substrate 12a enter a decompressed state, a resin curing process of curing the resin material, and an EL unification process of unifying the EL substrate 11a with the sealing material 133.

**[0090]** The following describes the process in detail, with reference to the drawings.

**[0091]** FIGS. 9A-9D illustrate the conjoining process. FIG. 9A illustrates the CF substrate and the EL substrate prior to joining. FIG. 9B illustrates the joined CF substrate and EL substrate. FIG. 9C illustrates the resin curing process. FIG. 9D illustrates the EL unification process.

**[0092]** Like FIGS. 8A-8D, each of FIGS. 9A-9D includes two drawings on the left-hand and right-hand sides, showing the same part of the process. The left-hand side is a perspective view diagram and the right-hand side is a cross-sectional diagram.

#### (a) Application Process

**[0093]** The sealant application process involves applying sealant 135a, 135b to the inside and outside of the sealing material 133 along the sealing material 133 formed in a longitudinal loop as seen in a plan view. Here, sealant 135a applied to the outside serves to prevent the intrusion of water, oxygen, and so on into the display region from outside, mainly during the resin curing process and the EL unification process. Also, sealant 135b applied to the inside serves to prevent sealing defects occurring due to intrusion, mainly of the resin material 136, between the sealing material 133 and the EL substrate 11, before the resin material 136 is baked.

**[0094]** The sealant may be any of epoxy resin, acrylic resin, silicone resin, phenol resin, melamine resin, and so on.

**[0095]** The resin material application process involves dripping the resin material 136 onto the display region. The resin material is dropped so as to be evenly distributed.

**[0096]** When the above-described sealant application process and resin material application process are complete, the substrate is as illustrated by the CF substrate 12a of FIG. 9A.

#### (b) Joining Process

**[0097]** As shown in FIGS. 9A and 9B, the joining process involves joining the CF substrate 12a resulting from the above-described application process with the EL substrate 11a resulting from the EL preparation process, such that the EL elements 30a of the EL substrate 11a and the colour filters 122a of the CF substrate 12a face each other.

#### (c) Decompression Process

**[0098]** The decompression process is decompression applied to the joined substrates. Decompression removes (i.e., enables the outgassing of) air (i.e., gas) in the resin material, air between the contact surfaces of the sealant 135 and the CF substrate 12a, and gasses built up during the baking of the frit paste 130. In order to improve the effect of escape, the CF substrate 12a may be decompressed alone prior to joining with the EL substrate 11a.

**[0099]** Here, the decompression process is performed after the joining process. However, the EL substrate 11a and the CF substrate 12a may undergo joining after decompression, and the resin material may be applied to the CF substrate 12a after decompression.

#### (d) Resin Curing Process

**[0100]** The resin curing process involves curing the resin material 136 between the EL substrate 11a and the CF substrate 12a. As shown in FIG. 9C, the curing method uses heat and ultraviolet rays. Once cured, the resin material forms the sealing resin 139.

#### (e) EL Unification Process

**[0101]** The EL unification process involves fusing the sealing material 133 and unifying the melted sealing material 133 with the EL substrate 11a. Specifically, this is performed

when the sealing material **133** is baked. The baking process is performed with the laser **137**, as shown in FIG. 9D.

[0102] Accordingly, the display region **131** is sealed by the sealing material **133**, such that the sealing material in this state has become the sealing member (**133**).

[0103] An intermediate panel **138** is produced by the EL substrate **11a** and the CF substrate **12a** joined to each other via the sealing member **133** and so on.

#### (4) Cutting Process

[0104] The cutting process is performed on the peripheral portions of the intermediate panel **138**. After cutting, the display panel **10** is produced. The cutting is performed by cutting along a rectangular frame **151** of the sealing member **133** in the intermediate panel **138**. The cutting may be performed using an implement such as diamond cutter, a laser scribe, or similar. The base line for cutting is a scribed line.

### 3. Application Process

[0105] The details of the application process are described below.

#### (1) Dispenser Device

[0106] FIGS. 10A-10C illustrate the dispenser device. FIG. 10A is a schematic illustration. FIG. 10B is a perspective view of the frit paste after application when the dispenser device has advanced directly. Similarly, FIG. 10C is a perspective view of the frit paste after application when the dispenser device has advanced rotationally.

[0107] The dispenser device **140** includes a discharge unit **141** accumulating and discharging the frit paste **130**, a measuring unit **142** measuring the distance from the glass substrate **121**, and a (non-diagrammed) control unit controlling the distance between the discharge unit **141** and the glass substrate **121** as measured by the measuring unit **142**, and adjusting the amount of frit paste **130** discharged by the discharge unit **141**.

[0108] In order to distinguish between the frit paste prior to application on the glass substrate **121** and the frit paste after application, reference sign **130** is used for the former and reference sign **145** is used for the latter.

[0109] The discharge unit **141** includes a cylinder **146** accumulating the frit paste **130** and a nozzle **147** provided at the bottom of the cylinder **146** and discharging the frit paste **130**. The nozzle **147** is continuous with a cylinder chamber within the cylinder **146**. The frit paste **130** is discharged by being pressurised within the cylinder chamber.

[0110] The measuring unit **142** measures the distance from the glass substrate **121**, which is positioned in front of the nozzle **147** relative to an advancement direction. The measurement is performed using a laser displacement sensor. The measured results are output to the control unit.

[0111] The control unit controls the pressure applied within the cylinder **146**, the movement speed of the discharge unit **141**, and the height of the nozzle **147** according to the results measured by the measuring unit **142**. The height and width of the frit paste **145** applied to the glass substrate **121** are determined by the pressure, the movement speed, and the nozzle height.

[0112] In the present Embodiment, as shown in the magnified portion of FIG. 10A, the control unit diminishes and maintains the distance between the glass substrate **121** and a bottom face **147a** of the nozzle **147**, and maintains the pres-

sure in the cylinder **146** (i.e., the amount of discharged frit paste **130**). Here, the height of the applied frit paste **145** is determined according to the space between the nozzle **147** and the glass substrate **121**.

[0113] As such, when the dispenser device **140** advances linearly as shown in FIG. 10B, the frit paste **145** dispensed onto the glass substrate **121** forms a straight line portion that is flat of uniform height and width.

[0114] Also, when the dispenser device **140** advances rotationally as shown in FIG. 10C, the frit paste **145** dispensed on the glass substrate **121** forms a flat disc of uniform height and width.

#### (2) Frit Paste Application Shape

[0115] FIGS. 11A and 11B are schematic diagrams of the frit paste as applied, where FIG. 11A is a perspective view and FIG. 11B is a magnified view of the vicinity of a corner of the rectangular frame.

[0116] As shown in FIG. 11, the frit paste **130** is applied so as to form the rectangular frame **151** and a plurality (in this example, four) reinforced portions **152**, **153**, **154**, and **155** (hereinafter, reinforced portions **152-155**). That is, the frit paste **145** is applied to become the rectangular frame **151** and the reinforced portions **152-155**.

##### (2-1) Rectangular Frame

[0117] The rectangular frame **151** surrounds the rectangular display region **131** (corresponding to the colour filter **122**) where the light-emitting elements are formed, and is rectangular as seen in a plan view. The rectangular frame **151** is configured from four edge portions, including a pair of long edge portions **156** and **158** extending along the longer dimension of the display region **131**, and a pair of short edge portions **157** and **159** extending along the shorter dimension of the display region **131**. Where no distinction between long and short edge portions is required, the edge portions are collectively referred to as edge portions **156-159**.

##### (2-2) Reinforced Portions

[0118] The reinforced portions **152-155** are provided on the outside of corner portions **160-163** of the rectangular frame **151**, so as to be continuous with the corner portions **160-163**. In other words, the reinforced portions **152-155** protrude outwardly from the corner portions **160-163** of the rectangular frame **151**. As seen in a plan view, the reinforced portions **152-155** are round and partially overlap (at a base portion) the corner portions **160-163** of the rectangular frame **151**.

[0119] As shown in FIG. 11B, the reinforced portions **152-155** are each arranged along a line E that bisects the internal angle of the corresponding corner portion of the rectangular frame **151**. In the present Embodiment, the center of each reinforced portion **152-155** (note that FIG. 11B shows only center **152a** reinforced portion **152**) is located along the line E bisecting the corresponding corner.

[0120] The reinforced portions **152-155** are continuous with the corresponding corner portions **160-163** of the rectangular frame **151**, and do not protrude inwardly toward the interior of the rectangular frame **151**. The reinforced portions **152-155** are formed with a greater curvature, and the portions connecting the reinforced portion **152-155** to the rectangular frame **151** are more smoothly linked, thus being beneficial in reducing stresses.

### (3) Application Method

[0121] FIGS. 12A-12C illustrate the frit paste application process. FIG. 12A illustrates the beginning of application. FIG. 12B illustrates a stage where one reinforced portion has been formed. FIG. 12C illustrates the completed frit paste application.

[0122] This application method is intended as an example, and no particular limitation is intended to the application method for the frit paste 145 having the rectangular frame 151 and the reinforced portions 152-155.

[0123] The application of the frit paste 130 onto the glass substrate 121 begins as shown in FIG. 12A, from a position F on border line 131a of the display region 131. The position F where application starts is the intersection of a planned position for long edge portion 156 and a planned position for short edge portion 159 (i.e., corner portion 163). Application of the frit paste 130 begins from position F and extends in a straight line along the border line 131a on the display region 131, to form (arrange) the long edge portion 156.

[0124] Eventually, upon reaching a planned position for short edge portion 157 (also the planned position for corner portion 160), the direction of movement changes by 90° and continues, going to advance and rotate until finally forming (arranging) reinforced portion 155.

[0125] Next, the remaining reinforced portions 152-154, which are round as seen in the plan view, are formed sequentially at the corner portions 160-162 of the rectangular frame 151 so as to connect to the corresponding corner portions 160-162. FIG. 12B shows reinforced portion 155 formed at the corner portion.

[0126] As shown in FIGS. 10A-10C, the reinforced portions 152-155 are formed by moving the dispenser device 140 to each reinforced portion formation position and rotating while dispensing the frit paste 130 (or by dispensing the frit paste 130 while rotating).

[0127] As shown in FIG. 12B, once reinforced portion 155 is formed, the dispenser device 140 is moved to the next reinforced portion formation position to form the other reinforced portions 152-154. The application of the frit paste 145 onto the glass substrate 121 is then complete, as shown in FIG. 12C.

[0128] Upon formation, the reinforced portions 152-155 will overlap (i.e., mix with) the corner portions 160-163 of the rectangular frame 151. However, given that the spacing between the nozzle 147 and the glass substrate 121 is fixed, this has the result of forming a rectangular frame 151 and reinforced portions 152-155 having a uniform height.

### 4. Cutting Process

[0129] FIG. 13 illustrates the cutting process.

[0130] As shown in FIG. 13, the cutting process is performed on the peripheral portions of the intermediate panel 138. FIG. 13 is a plan view of the intermediate panel 138. Normally, the sealing member 133 would not be visible, but has been bolded here for convenience of explanation. Also, the rectangular frame 151 and the reinforced portions 152-155 of the sealing member 133 use the same reference signs after baking.

[0131] As shown in FIG. 13, the cutting process involves cutting off the peripheral portions 138a-138d of the intermediate panel 138. Once the peripheral portions 138a-138d have been cut off, the resulting dimensions are those of the display panel 10. As shown in FIG. 13, the cutting process is per-

formed along scribed lines G1, G2, G3, and G4 (hereinafter, scribed lines G1-G4) each extending in parallel to one of the edge portions 156-159 making up the rectangular frame 151 of the sealing member 133, with predetermined spacing therefrom.

[0132] The spacing between the scribed lines G1-G4 and the edge portions is such that a piece of each reinforced portion 152-155 remains. That is, the scribed lines G1-G4 passes through the reinforced portions 152-155 such that the diamond cutter or laser scribe crosses the reinforced portions 152-155.

[0133] The size of the reinforced portions and the positions of the scribed lines G1-G4 are determined such that the intersections of the scribed lines G1-G4 occur within the reinforced portions 152-155. No particular limitation is intended to the order in which cutting is performed along the scribed lines G1-G4.

### 5. Strain Distribution

[0134] FIGS. 22A-22E illustrate strains in the sealing member.

[0135] FIGS. 22A-22E illustrate the intermediate panel prior to cutting according to conventional technology. FIG. 22A illustrates a case where the radius of the corner portions of the rectangular sealing member has been increased. FIG. 22B illustrates a case where the radius of the corner portions of the rectangular sealing member has been decreased. FIG. 22C is a magnified view of the common edge portions from FIGS. 22A and 22B. FIG. 22D is a magnified view of a corner portion from FIG. 22A. FIG. 22E is a magnified view of a corner portion from FIG. 22B.

[0136] FIG. 22A, in which the radius of the corner portions has been increased, and 22B, in which the radius of the corner portions has been decreased, are described first. The illustrated sealing members 905 and 911 are arranged between an EL substrate and a CF substrate and should have been drawn in dashed lines. However, solid lines are used in order to better illustrate the regions of the sealing members 905 and 911 and the perimeter thereof where stress and residual strain occurs.

[0137] In FIGS. 22C-22E, the arrows pointing toward the interior of the rectangular sealing members 905 and 911 represent residual stress in the substrate from the baking of the sealing members 905 and 911. This remaining stress is a tensile stress pulling in the direction of the arrow. Also, regions 909 and 915, drawn as an oval and circle respectively, indicate regions where strain remains.

[0138] The display region 903 is typically rectangular. Thus, the sealing member 905 is arranged rectangularly in conformity with the display region 903, and the corner portions have a large-radius arc as shown in FIG. 22A. Here, the portions of the sealing members 905 and 911 corresponding to corner portions of the display region 903 are identified as corner portions 907 and 913.

[0139] Making corner portion 907 into an arc with a large radius of curvature serves to prevent fractures (i.e., decreases in manufacturing efficiency) of the substrates upon cutting the periphery of the substrates that are joined together, occurring due to residual stress from the baking of the sealing member 905.

[0140] Fractures in the glass substrate are described next.

[0141] Fractures in the glass occur when pressure is applied that exceeds the bonding force between the atoms of the glass material. Generally, glass material is resistant to compression stress but vulnerable to tensile stress. On an atomic level, the

surface of the glass substrate has innumerable cracks. When the surface of the substrate experiences an outside physical force while the glass substrate is under tensile stress, moments of force are produced centered on the cracks, the outside force is concentrated on the cracks and causes them to expand, such that the cracks extend and fractures visible to the eye are produced in the glass substrate. Furthermore, substrate fractures are more likely to occur when intersecting tensile stresses are applied in two directions, rather than when tensile stress is applied in only one direction. When tensile stresses are applied in two directions, torsional stress occurs at the intersection thereof. Cracks are prone to extending from that point.

[0142] When the linear expansion coefficients of the sealing material and the glass substrate are not perfectly matched, then upon returning to room temperature after baking the sealing material, the tensile stresses on the glass substrate in the direction of the arrows continue to act as residual stresses. Among these residual stresses, as shown in FIG. 22C, the tensile stresses on edge portion 908 of the rectangle are unidirectional, acting orthogonally to the edge portion 908.

[0143] Also, in the vicinity of corner portion 913, when the corner is nearly a right angle as shown in FIG. 22B, the stresses acting on the corner portion 913 are as illustrated in FIG. 22E. Specifically, torsional stress occurs due to the tensile stresses acting in two directions, orthogonal to the respective edge portions 914a and 914b. As such, stresses are concentrated in the outer area near corner portion 911, and the probability of the substrate fracturing at that location greatly increases. Specifically, a problem may occur when outside force is applied during the scribing process, in that the EL substrate or the CF substrate may fracture in an unexpected direction at the corners of the intermediate panel 910.

[0144] In contrast, for corner portion 907 of the sealing member 905, when the corner is curved as shown in FIG. 22A, the direction of stress acting on the corner portion 907 changes gradually, as illustrated in FIG. 22D. Thus, torsional stress from two directions is less likely to occur, the tensile stresses are weaker than those acting on the right-angle corner portion 913 shown in FIG. 22B, and the probability of substrate fracture is reduced.

[0145] The above-described technology for arranging the sealing member 905 to have corner portions with a high radius of curvature in the display region 903 (i.e., FIG. 22A) is not amenable to reducing the width of the frame. According to conventional technology, a sealing member (911) with a corner portion (913) of the small radius shown in FIG. 22B and amenable to reducing the width of the frame has the scribed lines F1-F4 pass through region 915 where residual strain occurs, and is likely to fracture when the peripheral portions of the intermediate panel 910 are cut.

[0146] FIGS. 14A-14E illustrate the relationship between strain positions and scribed lines. FIG. 14A illustrates the intermediate panel pertaining to the present Embodiment. FIG. 14B illustrates a conventional intermediate panel. FIG. 14C is a magnified view of portions common to FIGS. 14A and 14B. FIG. 14D is a magnified view of a corner portion in FIG. 14A. FIG. 14E is a magnified view of a corner portion in FIG. 14B.

[0147] FIGS. 14A and 14B are a plan view of the respective intermediate panels 138 and 910. Normally, the sealing members 133 and 911 would not be visible, but have been bolded for convenience of explanation. Much like in FIGS. 22A-22E, the arrows indicate the orientation of the residual stresses.

[0148] The intermediate panels 138 and 910 are respectively subject to the stresses shown in FIGS. 14D and 14E.

#### (1) Residual Strain

[0149] As shown in FIG. 14B, edge portion 914 of the rectangular frame of the sealing member 911 is subject to stresses as shown in FIG. 14C, oriented toward edge portion 914 from both sides. Accordingly, stresses on each side cancel each other out, such that no region is subject to strong residual stresses and residual strain is unlikely to occur.

[0150] In contrast, corner portion 913 of the rectangular frame has a point where the tensile stresses operating perpendicularly to the edge portion 914 intersect, as shown in FIG. 14E. Accordingly, torsional stress is prone to occurring due to the tensile stresses in two directions, such that stress is concentrated at this point. Thus, stronger tensile stress occurs in region 915 outside corner portion 913. Given that stress is collected on the inside of corner portion 913, compression stress occurs but torsional stress is unlikely.

[0151] As shown in FIGS. 14A and 14D, intermediate panel 138 of the present Embodiment has reinforced portions 152-155, which are round as seen in a plan view, formed at the corner portions 160-163 where residual stresses are likely to be concentrated. Thus, stress (and strain) occurs in the regions 164-167 outside the reinforced portions 152-155.

[0152] The reinforced portions 152-155 are formed so as to extend outside the corner portions 160-163 of the rectangular frame 151, being shaped as circles with relatively large curvature as seen in a plan view. As such, regions 164-167 in the vicinity of the reinforced portions 152-155 serve to disperse the residual strain, as shown in FIG. 14D, and reduce the magnitude of stress per unit area.

[0153] The conventional intermediate panel 910 has, as shown in FIG. 14B, the rectangular sealing member 911 with corner portion 913 that is nearly a right angle. As such, the shape transition of corner portion 913 is sudden and dramatic. As shown in FIG. 14E, greater residual strain occurs in region 915 outside corner 913 than in regions 164-167 outside the reinforced portions 152-155 of the present Embodiment.

#### (2) Scribed Lines

[0154] The scribed lines G1-G4 on the intermediate panel 138 pertaining to the present Embodiment intersect the reinforced portions 152-155 as shown in FIG. 14A. Here, as shown in FIG. 14D, the scribed lines G1-G4 extend so as to avoid the respective centers of the regions 164-167 outside the reinforced portions 152-155 where residual strain occurs, thus preventing fracture of the intermediate panel 138 due to the residual strain.

[0155] Furthermore, the intermediate panel 138 pertaining to the present Embodiment experiences residual strain that is weaker than the residual strain occurring at corner portion 913 of the conventional intermediate panel 910, thus providing additional protection against intermediate panel fracture.

[0156] In contrast, as shown in FIG. 14B, the scribed lines H1-H4 of the conventional intermediate panel 910 pass through the region 915 outside the corner portion 913 where residual strain occurs. As such, residual strain is likely to cause fracturing of the intermediate panel 910.

[0157] Furthermore, the conventional intermediate panel 910 is subject to residual strain that is stronger than the residual strain dispersed throughout region 164 by the rein-

forced portion **152** of the intermediate panel **138** pertaining to the present Embodiment, thus becoming more prone to fracturing.

## 6. Multipanel Method

[0158] An example is described above in which one display panel **10** is manufactured from one intermediate panel **138**. However, the above-described example is also applicable to manufacturing a plurality of display panels **10** from a large intermediate panel containing a plurality of smaller intermediate panels (hereinafter termed a multipanel method). An example of the multipanel method is described below.

[0159] FIG. **15** illustrates an example of frit paste application in the multipanel method for display panels.

[0160] As shown in FIG. **15**, a large plate **171** is a glass substrate having four display regions **173**, **174**, **175**, and **176** formed thereon. The four display regions are arranged in a matrix (here, a 2x2 matrix). The display regions **173-176** are referred to collectively where there is no need to distinguish between individual display regions.

[0161] Frit paste **177-180** is applied to the large plate **171** in the display regions **173-176**. The frit paste **177-180** is applied so as to surround the display regions **173-176** with a rectangular frame, and to form the reinforced portions at the outside of the corner portions of each rectangular frame.

[0162] The cutting process of cutting out the four intermediate panels from a large intermediate panel formed by joining the large plate **171** to another large plate serving as an EL substrate on which are formed pixels corresponding to the four display regions is performed by cutting through the reinforced portions of each intermediate panel, as described for the single-panel example above.

### Embodiment 2

[0163] As shown in FIG. **13**, Embodiment 1 describes cutting the EL substrate and the CF substrate to identical dimensions. That is, the cut face (i.e., side face) of the EL substrate and the cut face (i.e., side face) of the CF substrate are cut so as to match along the entire respective perimeters thereof.

[0164] However, the EL substrate and the CF substrate may differ in terms of dimensions. Embodiment 2 describes an example of such a case (i.e., where the cut faces do not match).

#### 1. Mono-Panel Method

[0165] FIGS. **16A** and **16B** illustrate an example pertaining to Embodiment 2 in which the display panel has substrates of different dimensions. FIG. **16A** is a plan view of the display panel and FIG. **16B** is a magnified perspective view of a corner of the intermediate panel.

##### (1) Overview

[0166] A display panel **300** has a display region **302** sealed by a sealing member **305** when an EL substrate **301** and a CF substrate **303** are joined to each other. As indicated by the dashed line in FIG. **16A**, the sealing member **305** has a rectangular frame **307** and four reinforced portions **309**. The reinforced portions **309** extend from the corner portions of the rectangular frame **307** toward the outside.

[0167] In terms of overall rectangular shape in a plan view, the EL substrate **301** and the CF substrate **303** are cut such that, as shown in FIG. **16B**, side face **309a** of one of the reinforced portions **309** is aligned with respective side face

**301a** of the EL substrate **301** and side face **303a** of the CF substrate **303**. That is, one of the reinforced portions **309** has side face **309a** cut so as to be flush with side faces **301a** and **303a** at the respective corner portions of the EL substrate **301** and the CF substrate **303**. Being flush signifies that at least two faces are included within the same virtual plane.

[0168] As shown in FIG. **16A**, the reinforced portions **309** have not only side face **309a** but also side faces **303b-303h** match the side faces of EL substrate **310** and CF substrate **303** at the respective corner portions.

[0169] EL substrate **301** is rectangular as seen in the plan view, and has side faces **J1-J4**. The CF substrate **303** has an overall shape that is rectangular as seen in the plan view. Side faces **I1-I4** of the CF substrate **303** each have at least one part (between two neighbouring corner portions at the outer perimeter of the rectangle) that, in the plan view, is arranged inwardly (i.e., closer to the center) relative to a line extending from side portions **303a-303h** of the corner portions of the CF substrate **303**. That is, side faces **I1-I4** each have a portion between two corner portions that is more indented toward the center of the CF substrate **202** than side portions **303a-303h** of the CF substrate **303** and the side faces of the EL substrate **301**, with respect to the reinforced portions **309**.

[0170] Also, at least part (between two neighbouring corner portions at the outer perimeter of the rectangle) of side faces **I1-I4** of the CF substrate are arranged closer to the centers of the CF substrate **303** and the EL substrate **301** than side faces **J1-J4** of the EL substrate **301**.

[0171] Electrodes **311** for providing an electrical connection to the outside are formed outside the edges of the rectangular frame **307** of the sealing member **305** on the face of the EL substrate **301** opposite the CF substrate **303**. The electrodes **31** are exposed due to the two neighbouring corner portions in the circumferential direction of the CF substrate being indented toward the center.

##### (2) CF Substrate Shape

[0172] As shown in FIG. **16A**, the CF substrate **303** has side faces **303i-303p** that extend toward the display region **302** from the outside of the rectangular frame **307** of the sealing member **305**, at the corner portions.

[0173] Conventionally, the scribed lines are formed so as to extend toward the display region of the display panel and cutting of the CF substrate and the EL substrate is not performed along these scribed lines. This is done because forming the scribed marks on the substrate using a diamond scribe is prone to causing fissures in the substrate along the direction in which the scribed marks were drawn. In recent years, particularly, with an aim to decreasing costs and creating lighter products, a trend has emerged toward using thinner glass for the CF substrate and so on, which means that the substrates are more likely to fracture.

[0174] However, in Embodiment 2, a conventional diamond scribe is not used to cut the CF substrate **303**. A diamond cutter or laser scribe is used instead, so as to constrain the risk of fissures occurring in the substrate when the scribe marks are formed. As such, Embodiment 2 enables cutting of the CF substrate **303** having side faces **303i-303p** oriented toward the display region **302**, and is applicable to thinning the substrate.

##### (3) Fixing Material

[0175] A fixing material is used to fix the EL substrate **301** and the CF substrate **303** so as to achieve more secure joining

thereof. For example, the fixing material may be used in the manufacturing process of curing the resin material 136 disposed between the EL substrate 301 and the CF substrate 303, and may be contained within the display device along with the display panel 300, when mounted.

[0176] FIGS. 17A-17D illustrate the use of the fixing material to join the EL substrate to the CF substrate. FIG. 17A illustrates a case where the display panel pertaining to Embodiment 2 is used. FIG. 17B is an expanded view of a cross-section of FIG. 17A taken along line X1-X2. FIG. 17C illustrates a case where a conventional display panel is used. FIG. 17D is an expanded view of a cross-section of FIG. 17C taken along line X3-X4.

[0177] FIGS. 17A and 17C are front views of the respective display panels, with a portion of the fixing material taken away.

[0178] In this example, a frame 315 is used for the fixing material. The frame 315 is made up of two members dividing the frame area into at least two portions as seen in the plan view, so as to enabling mounting of the four sides of the rectangular display panel 300.

[0179] As shown in FIGS. 17A and 17C, the frame 315 includes a pair of plate portions 315a and 315b extending along the front and back faces of the display panel 300, leaving a gap corresponding to the thickness of the display panel, and a connecting portion 315c connecting the ends (i.e., on the outside of the display panel 300) of the pair of plate portions 315a and 315b. A lateral cross-section of the frame 315 includes a U-shaped opening in the side of the display panel 300.

[0180] The pair of plate portions 315a and 315b are made from an elastically deformable material. Also, the spacing of the pair of plate portions 315a and 315b grows increasingly narrower toward the far ends (i.e., with distance from the center of the display panel 300). Accordingly, when the peripheral portions of the display panel 300 are inserted between the pair of plate portions 315a and 315b, a load is imposed in the thickness dimension of the EL substrate 301 and the CF substrate 303 that acts to maintain the joining thereof.

[0181] FIGS. 17C and 17D illustrate a situation where the frame 315 is fitted into a conventional display panel 920. As shown in FIG. 17C, display panel 920 is configured such that CF substrate 921 is smaller than EL substrate 923 when the CF substrate 921 is arranged over the EL substrate 923 and seen in a plan view.

[0182] Thus, as seen in FIG. 17D, when the frame 315 is mounted on the display panel 920, the contact surface area between plate portion 315a and CF substrate 921 is smaller and the compression stress acting on the peripheral portions of the CF substrate 921 is greater, which makes the peripheral portions more prone to breaking.

[0183] Also, when the display panel 920 is placed between the pair of plate portions 315a and 315b, the position of the sealing member 913 is such that the positions of plate portion 315a near the CF substrate 921, CF substrate 921, the sealing member 913, EL substrate 923, and plate portion 315b near the EL substrate 923 are directly aligned.

[0184] However, the peripheral portions of EL substrate 923 protrude from the sealing member 913 toward the exterior. When these protruding portions are subjected a compression load from plate portion 315b, the peripheral portions of EL substrate 923 begin to bend. This deformation poses a risk

that the CF substrate 921 and the sealing member 913, or the EL substrate 923 and the sealing member 913, may peel apart.

[0185] Next, the mounting of the frame 315 onto the display panel 300 pertaining to Embodiment 2 is described with reference to FIGS. 17A and 17B. The display panel 300 has been cut at the corner portions to match the dimensions of the CF substrate 303 and the EL substrate 301. The reinforced portions 309 of the sealing member 305 are located between the corner portions of the CF substrate 303 and the EL substrate 301.

[0186] Accordingly, as seen in a lateral cross-section, the positions of plate portion 315a near the CF substrate 303, CF substrate 303, the reinforced portion 309, EL substrate 301, and plate portion 315b near the EL substrate 301 are directly aligned. Thus, although the pair of plate portions 315a and 315b sandwich the display panel 300 by applying a strong force, the corner portions withstand the load such that the EL substrate 301 and the CF substrate 303 undergo less bending at the middle portions of the edges thereof. Accordingly, bending and deformation of the CF substrate 303 and the EL substrate 301 are constrainable, with the result that the CF substrate 303 and the EL substrate 301 are prevented from peeling apart.

[0187] In the event that cracks occur at the corner portions of the CF substrate 303, the reinforced portions 309 serve to fix the CF substrate 303 such that the CF substrate 303 is unlikely to undergo further deformation, thereby constraining the further spread of the cracks.

[0188] Also, the corner portions have the reinforced portions 309 of the sealing member 305 covering a wide area of the EL substrate 301 and the CF substrate 303, such that the bending load on the periphery of the EL substrate 301 and the CF substrate 303 is reduced. Accordingly, the reinforced portions 309 are unlikely to peel apart from the CF substrate 303 and the EL substrate 301.

[0189] Further, the corner portions of the display panel 300 are prone to receiving outside forces during the manufacturing process, and are thus likely to break. As such, reinforcing the corner portions of the display panel 300 is important, in terms of manufacturing efficiency, for constraining peeling and deformation.

#### (4) Other

[0190] In Embodiment 2, the reinforced portions 309 are formed only at the corner portions of the display panel 300. However, other portions may also be reinforced. A variation of Embodiment 2, in which the reinforced portions are also formed elsewhere, is described below.

[0191] FIGS. 18A and 18B illustrate the variation of Embodiment 2.

[0192] As shown, the display panel 320 has the EL substrate 321 and the CF substrate 323 conjoined by the sealing member 324 located therebetween. The sealing member 324 includes a rectangular frame 325 provided along the center of a display region 326, reinforced corner portions 327a provided at the corner portions of the display panel 320, and reinforced middle portions 327b provided at middle portions between the corners.

[0193] The reinforced corner portions 327a are configured similarly to the reinforced portions 309 of Embodiment 2. The reinforced middle portions 327b are provided during the sealing material (i.e., frit paste) application process by applying the sealing material at the center of each edge portion of

the rectangular frame **325** so as to extend outward, away from the center of the display region **326**.

[0194] The reinforced middle portions **327b** need only be arranged at the outside of the rectangular frame **325**, which is the outside of the display region **326**. No particular limitation to the shape thereof is intended. In this example, the shape is oval. However, the shape may also be round, oblong, square, or some other polygon.

[0195] As shown in FIGS. **18A** and **18B**, the CF substrate **323** has an overall shape that is rectangular, and includes concavities **322a-322h** and **322i-322p** at the edges thereof. In other words, the CF substrate **323** has a shape conforming to the sealing member **324**. That is, corner portions **324a-324d** corresponding to the reinforced corner portions **327a** and middle portions **324e-324h** corresponding to the reinforced middle portions **327b** extend outward further than the corresponding portions of the rectangular frame **325**.

[0196] The concavities at the edges may be linear concavities at the side faces, as illustrated by concavities **322a-322h** in FIG. **18A**, or may be curved concavities at the side faces as illustrated by concavities **322i-322p** in FIG. **18B**.

[0197] The EL substrate **321** includes electrodes **329** on faces opposite the CF substrate **323** and corresponding to the concavities **322a-322h** and **322i-322p**.

[0198] The middle portions **324e-324h** of the CF substrate **323** are conjoined to the EL substrate **321** via the reinforced middle portions **327b**. Accordingly, the display panel **320** has not only the corner portions but also the middle areas between corners acting, via the fixing material (e.g., the frame **315**), to fix the EL substrate **321** and the CF substrate **323**. Having the reinforced middle portions **327b** enables, for example, a reduction in deformation of the substrates between corner portions of the EL substrate **321** and the CF substrate **323**.

[0199] Although the middle portions **324e-324h** are defined as the approximate midpoint between corner portions of the CF substrate **321**, other positions are also possible, and the middle portions may also be provided in plurality at each edge. For example, appropriate positioning may be determined according to the design of the display panel **320** and the positions of electrodes or wiring extending from the display region (or display area) **326**.

## 2. Multi-Panel Method

[0200] The following describes a multi-panel method using a large intermediate panel **339** as the display panel described above.

[0201] FIG. **19** illustrates the large intermediate panel used for the multi-panel method applied to the display panel.

[0202] FIG. **19** is a plan view of the large intermediate panel. However, the display region and sealing member are drawn in solid lines rather than in dashed lines so as to better illustrate the interior configuration.

[0203] As shown, the large intermediate panel **331**, as provided when a large EL substrate and a large CF substrate are joined together, includes a plurality (here, four) of display regions **331**, **333**, **335**, **337** (where no distinction between display regions is needed, the display regions are collectively referred to as display regions **331-337**).

[0204] The display regions **331-337** are sealed by sealing members **341**, **343**, **345**, **347** (where no distinction between sealing members is needed, the sealing members are collectively referred to as sealing members **341-347**) disposed therearound. The four display regions are arranged in a matrix (here, a 2x2 matrix).

[0205] The frit paste is applied to the substrate so as to surround the display regions **331-337** with a rectangular frame, and to form the reinforced portions at the outside of the corner portions of each rectangular frame. That is, the sealing members **341-347** each include a rectangular frame surrounding the respective display region **331-337**, and reinforced portions arranged at the outside of the corner portions of each rectangular frame.

[0206] The cutting of the four display panels from the large intermediate panel is described next.

[0207] FIGS. **20A-20C** illustrate the cutting of the display panels from the large intermediate panel. FIGS. **20A** and **20B** show the large intermediate panel as seen from the CF substrate, and FIG. **20C** shows the large intermediate panel as seen from the EL substrate.

[0208] FIGS. **20A-20C** are plan view of the large intermediate panel. However, the display region and sealing member are drawn in solid lines rather than in dashed lines so as to better illustrate the interior configuration, such as electrode positions.

[0209] Here, the cutting of the display panels is performed using a laser. That is, a laser scribe is used to cut the large intermediate panel while power is being adjusted.

[0210] The cutting process includes: an EL perimeter cutting process of cutting the EL substrate **351** along the perimeter of each sealing member **341-347**, formed as rectangles in the plan view, so as to pass through each reinforced portion; a CF perimeter cutting process of cutting the CF substrate **353** along the perimeter of each sealing member **341-347**, formed as rectangles in the plan view, so as to pass through each reinforced portion; and a CF inter-corner cutting process of cutting the CF substrate **353** so as to form the concavities between each pair of neighbouring corners in the circumferential directions of the respective sealing members. No particular limitation is intended to the order of the above-listed processes. The processes may be performed in the above order, or the alternative below may be used.

### (1) CF Perimeter Scribing Process

[0211] As shown in FIG. **20A**, the CF perimeter cutting involves cutting around the rectangular frame of each sealing member **341-347** so as to pass through the reinforced portions disposed around the sealing members **341-347** (the cut face of each reinforced portion corresponding to the second face of the disclosure). Thus, vertical (column direction) and horizontal (row direction) scribed lines (e.g., **K1-K6**) are first drawn in a matrix, extending between neighbouring display regions, so as to form scribed marks on the surface of the CF substrate **353**.

### (2) CF Inter-Corner Scribing Process

[0212] As shown in FIG. **20B**, the CF inter-corner cutting involves cutting the CF substrate **353** along the edges of the sealing members **341-347**, which form rectangles on the CF substrate **353**. Thus, scribed marks are first formed on the surface of the CF substrate **353** by tracing oblong scribed lines **L1-L4** so as to bridge neighbouring display panels in the row direction or in the column direction.

[0213] Also, scribed marks are formed on the surface of the CF substrate in portions thereof corresponding to the ends of the rows and columns, as semi-oblong scribed lines **L5-L8**.

## (3) EL Perimeter Scribing Process

[0214] As shown in FIG. 20C, the EL perimeter cutting involves cutting around the rectangular frame of each sealing member 341-347 so as to pass through the reinforced portions disposed around the sealing members 341-347 (the cut face of each reinforced portion corresponding to the first face of the disclosure). Thus, vertical (column direction) and horizontal (row direction) scribed lines (e.g., M1-M6) are first drawn in a matrix, extending between neighbouring display regions, so as to form scribed marks on the surface of the EL substrate 351.

(4) Cleavage Process Mechanical force is applied to the vicinity of the scribed lines drawn in parts (1)-(3), and the CF substrate 353 and the EL substrate 351 are then twisted so as to cause cleavage along the scribed lines of the CF substrate 353 and the EL substrate 351. As for the reinforced portions of the sealing members 341-347, given that the scribed lines (e.g., K1-K6) of the CF substrate 353 and the scribed lines (e.g., M1-M6) of the EL substrate 351 are in the same place, and that in addition, the thickness of the reinforced portions (e.g., 0.01 mm) is sufficiently small in comparison to the thickness of the glass substrate (0.7 mm), cleavage is easily made to occur along identical lines.

[0215] <Variations>

## 1. Manufacturing Method

## (1) Paste Application Substrate

[0216] In the above Embodiments, the frit paste 130 is applied to the glass substrate 121 intended for the CF substrate. However, the application process of the frit paste 130 may also be performed on the substrate intended for the EL substrate. In such a case, the EL elements (i.e., light-emitting elements) may be formed after the unification process of the frit paste.

## (2) Application Process

[0217] In the Embodiments, the frit paste 130 application is performed using a dispenser method that employs a nozzle. However, a screen printing method employing a screen mask may be used instead.

## (3) Frit Paste Unification Process

[0218] Although the frit paste unification process is described as using the laser 132 to have the frit in the frit paste 145 adhere to the glass substrate 121, another method may also be used to the same end. Other methods include disposing the glass substrate having the frit paste thereon in a furnace and heating until the temperature reaches the fusion point of the frit paste (i.e., the sealing material), thereby causing the unification of the sealing material and the substrate.

## (4) CF Formation Process

[0219] The CF formation process is performed after the frit paste unification process. However, when the frit paste unification process is performed via heating using the laser 132, a smaller portion of the glass substrate is subject to heating and the effect of the heat on the colour filters 122a is reduced. As such, the CF formation process may be performed before the frit paste unification process with the laser, or before the application process of the frit paste 145.

[0220] That is, when the laser is used for fusing the frit paste, the process order may be CF formation, frit paste application, frit paste unification process, or may be frit paste application, CF formation, frit paste unification process.

## 2. Reinforced Portions

## (1) Plan View

[0221] In the Embodiments, the reinforced portions 152-155 and 309 are formed at the outside of the respective rectangular frames 151 and 307 so as to be connected to the corresponding corner portions of the rectangular frames 151 and 307, the reinforced portions 152-155 and 309 being round as seen in the plan view. However, other configurations are also possible.

[0222] Other shapes include oval, oblong, triangular, and other polygonal shapes. In consideration of the changes in residual strain occurring along the perimeter of the different shapes, a round, oval, or oblong shape is preferable. For polygonal shapes, corner portions are beneficially rounded off.

## (2) Structure

[0223] In the Embodiments, the reinforced portions 152-155 are round and filled in with the frit paste. However, the reinforced portions need only be connected to the corresponding corner portions of the rectangular frame and arranged on the outside thereof. No particular importance is given to the point regarding whether or not the reinforced portions are filled in with the frit paste.

[0224] FIGS. 21A-21C illustrate other examples of the reinforced portions labelled Examples 1-3. FIG. 21A illustrates a reinforced portion pertaining to Example 1, FIG. 21B illustrates a reinforced portion pertaining to Example 2, and FIG. 21C illustrates a reinforced portion pertaining to Example 3.

## (a) Example 1

[0225] As shown in FIG. 21A, reinforced portion 501 pertaining to Example 1 is arranged at the outside of a corner portion 505 of rectangular frame 503 so as to be continuous with the corner portion 505. The reinforced portion 501 is round as seen in the plan view, and the interior thereof is not filled by the frit paste.

[0226] The reinforced portion 501 is formed so as to bridge edge portion 507 and edge portion 509, which meet at corner portion 505 of the rectangular frame 503. In other words, the reinforced portion 501 is formed so as to extend from one edge portion of the corner portion 505 (e.g., edge portion 507) and curve in a circle before continuing to the other edge portion (e.g., edge portion 509).

[0227] According to this configuration, the frit paste is applied with a single stroke, thus enabling more efficient frit paste application.

## (b) Example 2

[0228] The reinforced portion 501 of Example 1 is shaped as a circle extending from two edge portions (507, 509) of the corner portion (505). However, other polygonal shapes are also possible. Example 2 illustrates an example of a quadrilateral extending from the corner portion.

[0229] As shown in FIG. 21B, reinforced portion 511 pertaining to Example 2 is arranged at the outside of a corner

portion **515** of rectangular frame **513** so as to be continuous with two edge portions **517** and **519** that meet at the corner portion **515**. The reinforced portion **511** is a quadrilateral as seen in the plan view, extending from edge portion **517**, which is one of the two edge portions meeting at the corner portion (**515**), so as to trace a square before connecting to the other edge portion **519**. The square so traced has rounded corners.

(c) Example 3

[0230] As shown in FIG. 21C, reinforced portion **521** pertaining to Example 3 is arranged at the outside of a corner portion **525** of rectangular frame **523** so as to be continuous with the corner portion **525**. The reinforced portion **521** is angular as seen in the plan view. The reinforced portion **521** includes two connecting portions **521a** and **521b** connected to the two edge portions (**527**, **529**) meeting at the corner portion **525** of the rectangular frame **523**, and a curved portion **521c** curving in an arc along the corner portion **525**.

[0231] When the frit paste of the reinforced portion **521** is applied using the dispenser method, for example, application first proceeds from an end of edge portion **527** at the corner portion **525** toward a midpoint of the edge portion **527** along the outside thereof before returning, and then extending along a straight line conforming to the rectangular frame **523**, curving in an arc corresponding to the corner portion **525** upon reaching the corner portion **525** of the rectangular frame **523**, extending along the other edge portion **529**, and finally returning to the other end of the edge portion **529**.

[0232] Here, the two edge portions **517** and **519** meeting at the corner portion **515** may be directly connected as in FIG. 21B, or may be somewhat separated as in FIG. 21C.

(3) Positioning

[0233] In the Embodiments, the center of each reinforced portion **152-155** is, as shown in FIG. 11B, arranged along line E bisecting the internal angle of the corresponding corner portion of the rectangular frame **151**. This is done because arranging the center of the reinforced portion along the bisecting line causes the region where the residual strain from outside the reinforced portion is greatest (portions **164-167** in FIGS. 14A-14E) to occur away from the scribed lines (lines G1-G4 in FIG. 14A), thus preventing breakage of the intermediate panel **138** during the cutting process.

[0234] Accordingly, the positioning of the reinforced portions may be any positioning such that the greatest residual stress produced at the outside of the reinforced portions does not occur on the scribed lines, and need not necessarily be such that the center of the reinforced portions is on the bisecting line.

[0235] In consideration of the residual strain in the display panel, having the greatest residual stress occur along a diagonal of the rectangular frame is beneficial in terms of balance in the overall strain.

(4) Other

[0236] In the Embodiments, all four reinforced portions **152-155** are the same in terms of shape and size. However, this need not necessarily be the case. For example, the reinforced portions along the same diagonal of the rectangular frame may be of the same shape and size, with the shape and size changing for each of the diagonals. Alternatively, each of the reinforced portions may have a different shape and size.

However, a sufficient portion of the reinforced portion must be present along the scribed lines.

3. Rectangular Frame

[0237] In the Embodiments, the rectangular frame **151** is formed so as to be rounded at the inner sides of the corner portions. However, the inner sides of the corner portions may also be substantially right angles as in Example 2, above, or may be discontinuous as in Example 3, above.

INDUSTRIAL APPLICABILITY

[0238] The present disclosure is widely applicable to applying paste to a first substrate.

REFERENCE SIGNS LIST

- [0239] **10** Display panel
- [0240] **14** EL substrate
- [0241] **12** CF substrate
- [0242] **13** Sealing resin layer
- [0243] **145** Frit paste
- [0244] **151** Rectangular frame
- [0245] **152-155** Reinforced portions
  1. A display panel, comprising:
    - a first substrate;
    - a second substrate arranged opposite the first substrate;
    - a plurality of electroluminescence elements disposed between the first substrate and the second substrate; and
    - a sealing member provided between the first substrate and the second substrate, sealing the electroluminescence elements, wherein
  - the sealing member includes a rectangular frame formed along a perimeter of the electroluminescence elements, and a reinforced portion protruding outward from a corner portion of the rectangular frame,
  - the reinforced portion includes a first side face cut so as to be flush with at least one corner side face of the first substrate, and a second side face cut so as to be flush with a corresponding corner side face of the second substrate, and
  - the first side face and the second side face are coplanar.
  2. The display panel of claim 1, wherein
  - the electroluminescence elements are mounted on the first substrate, and
  - a side face of the second substrate is indented toward a second substrate center with respect to a line extending from the corner side face of the second substrate.
  3. The display panel of claim 2, wherein
  - an indented portion of the side face of the second substrate is closer to the second substrate center than a side face of the first substrate is to the second substrate center.
  4. The display panel of claim 1, wherein
  - the sealing member is frit glass.
  5. The display panel of claim 1, wherein
  - the sealing member further includes a reinforced middle portion protruding outward from an inter-corner portion of the rectangular frame.
  6. A manufacturing method for a display panel, comprising:
    - forming a plurality of electroluminescence elements within a central region of a first substrate;
    - using a sealing material to provide, on one of the first substrate and a second substrate, a rectangular frame surrounding a region corresponding to the central region

and a reinforced portion protruding outward from a corner portion of the rectangular frame;  
sealing the electroluminescence elements by joining the first substrate and the second substrate with the sealing material interposed therebetween; and  
cutting the first substrate and the second substrate, wherein cutting the first substrate and the second substrate involves cutting the reinforced portion while overlapping with respective corner portions of the first substrate and the second substrate, as viewed from a joining direction.

**7.** The manufacturing method of claim **6**, wherein the reinforced portion is cut while simultaneously overlapping with both of the respective corner portions of the first substrate and the second substrate, as viewed from the joining direction, such that overlapping portions are flush.

**8.** The manufacturing method of one of claim **6**, wherein the second substrate is cut such that a side face thereof is indented toward a second substrate center with respect to a line extending from the corner portion.

**9.** The display panel of claim **3**, wherein the sealing member is frit glass.

**10.** The display panel of claim **9**, wherein the sealing member further includes a reinforced middle portion protruding outward from an inter-corner portion of the rectangular frame.

**11.** The manufacturing method of claim **7**, wherein the second substrate is cut such that a side face thereof is indented toward a second substrate center with respect to a line extending from the corner portion.

\* \* \* \* \*

专利名称(译)	显示面板和显示面板的制造方法		
公开(公告)号	<a href="#">US20140184059A1</a>	公开(公告)日	2014-07-03
申请号	US14/240416	申请日	2013-05-17
申请(专利权)人(译)	松下电器产业株式会社		
当前申请(专利权)人(译)	JOLED INC		
[标]发明人	MASUDA HIROYUKI		
发明人	MASUDA, HIROYUKI		
IPC分类号	H05B33/04 H05B33/10		
CPC分类号	H05B33/10 H05B33/04 H01L51/5246		
优先权	2012114850 2012-05-18 JP		
其他公开文献	US9095018		
外部链接	<a href="#">Espacenet</a>	<a href="#">USPTO</a>	

摘要(译)

一种显示面板，包括第一基板，与第一基板相对设置的第二基板，设置在第一基板和第二基板之间的电致发光元件，以及设置在第一基板和第二基板之间的密封构件，用于密封电致发光元件。密封构件包括沿着电致发光元件的周边形成的矩形框架和从矩形框架的角部向外突出的加强部分，加强部分包括切割成与至少一个角侧齐平的第一侧面第一基板的面，第二侧面切割成与第二基板的相应的角侧面齐平。

